

FAS2 Femtostat

Operator's Manual

Copyright© 1995-2003, Gamry Instruments, Inc. All rights reserved. Printed in the USA.

Revision 4.2

April 15, 2003

Limited Warranty

Gamry Instruments, Inc., warrants to the original user of this product that it shall be free of defects resulting from faulty manufacture of the product or its components for a period of two years from the date of shipment.

Gamry Instruments, Inc., makes no warranties regarding either the satisfactory performance of the FAS2 or the fitness of the instrument for any particular purpose. The remedy for breach of this Limited Warranty shall be limited solely to repair or replacement, as determined by Gamry Instruments, Inc., and shall not include other damages.

Gamry Instruments, Inc., reserves the right to make revisions to the FAS2 at any time without incurring any obligation to install same on instruments previously purchased. All instrument specifications are subject to change without notice.

There are no warranties which extend beyond the description herein. This warranty is in lieu of, and excludes any and all other warranties or representations, expressed, implied or statutory, including merchantability and fitness, as well as any and all other obligations or liabilities of Gamry Instruments, Inc., including but not limited to, special or consequential damages.

This limited warranty gives you specific legal rights and you may have others which vary from state to state. Some states do not allow for the exclusion of incidental or consequential damages.

No person, firm, or corporation is authorized to assume for Gamry Instruments, Inc., any additional obligation or liability not expressly provided herein except in writing duly executed by an officer of Gamry Instruments, Inc.

Disclaimers

Gamry Instruments, Inc., cannot guarantee that the FAS2 Femtostat will work with all computer systems, operating systems, and third party expansion cards and peripherals.

The information in this manual has been carefully checked and is believed to be accurate as of the time of printing. However, Gamry Instruments, Inc., assumes no responsibility for errors that might appear.

Copyrights and Trademarks

FAS2 Femtostat Operator's Manual Copyright© 1995-2003 Gamry Instruments, Inc. All rights reserved.
Printed in the USA.

Gamry Framework Copyright© 1989-2003 Gamry Instruments, Inc.

Femtostat™, FAS2™, PCI4™, Gamry Framework™, DC105™, EIS300™, and Gamry™ are trademarks of Gamry Instruments, Inc.

Windows™ is a trademark of Microsoft Corporation

No part of this document may be copied or reproduced in any form without the prior written consent of Gamry Instruments, Inc.

If You have Problems

Contact us at your earliest convenience. We can be contacted via:

Telephone	(215) 682-9330 8:00 AM - 6:00 PM US Eastern Standard Time
Fax	(215) 682-9331
Email	techsupport@gamry.com
Mail	Gamry Instruments, Inc. 734 Louis Drive Warminster, PA 18974 USA

If you write to us about a problem, provide as much information as possible.

If you are having problems with installation or use of your FAS2 Femtostat, it would be helpful if you called from a phone near to your computer, where you can type and read the screen while talking to us.

We are happy to provide a reasonable level of free support for registered users of our products. Reasonable support includes telephone assistance covering the normal installation and use of the FAS2 in standard computer hardware.

We provide a two year warranty covering both parts and labor. A service contract that extends the warranty is available at an additional charge.

Enhancements to the FAS2 that require significant significant engineering time on our part may be available on a contract basis. Contact us with your requirements.

Table of Contents

Limited Warranty.....	i
Disclaimers	ii
Copyrights and Trademarks.....	ii
If You have Problems.....	iii
Chapter 1 -- Introduction.....	1-1
About This Manual.....	1-1
CE Compliance Required for Sale in Europe.....	1-1
About the FAS2.....	1-2
FemtoStat Schematic Diagram	1-3
Notational Conventions.....	1-7
Chapter 2 -- Installation.....	2-1
Computer Requirements.....	2-1
PCI Compatibility.....	2-2
Positional Conventions	2-2
Handling the FAS2 Controller Card	2-3
Multiple Potentiostat Systems	2-4
Plug & Play System Configuration	2-4
Installing the Controller Card in Your Computer.....	2-5
Connecting the FAS2 Interconnection Cable to the Controller Card.....	2-6
Connecting the Potentiostat Module to the Controller Card.....	2-6
Application Software Installation and System Checkout	2-8
Calibration	2-8
Chapter 3 -- Cell Lead Connections.....	3-1
Cell Indicator.....	3-1
Cell Connections.....	3-1
Chapter 4 -- Stability in Potentiostat Mode.....	4-1
Capacitive Cells and Stability	4-1
Improving Potentiostat Stability.....	4-2
Chapter 5 -- Measurement of Small Signals.....	5-1
Overview	5-1
Measurement System Model and Physical Limitations.....	5-1
Johnson Noise in Z_{cell}	5-3
Finite Input Capacitance.....	5-4
Leakage Currents and Input Impedance	5-5
Voltage Noise and DC Measurements.....	5-5

Shunt Resistance and Capacitance.....	5-6
Hints for System and Cell Design	5-7
Faraday Shield	5-7
Avoid External Noise Sources	5-8
Cell Lead Length and Construction.....	5-8
Lead Placement.....	5-8
Cell Construction	5-9
Reference Electrode.....	5-9
Instrument Settings.....	5-9
EIS Speed	5-10
Ancillary Apparatus.....	5-10
Floating Operation.....	5-10
Appendix A -- Specifications.....	6-1
Appendix B -- Changing The Default FAS2 Settings	6-6
Overview	6-6
About the "GAMRY.INI" File	6-7
Changing "GAMRY.INI" using Setup.....	6-10
Using Notepad to alter "GAMRY.INI".....	6-10
Removing a Potentiostat from an Existing System.....	6-10
Interrupt Level Setting.....	6-10
Register Address.....	6-11
Changing the Auxiliary Analog Output Scaling.....	6-11
Appendix C -- I/O Connections for the FAS2	6-12
Grounds and the FAS2 Femtostat	6-12
The Cell Connections.....	6-13
Aux A/D Input.....	6-13
Control Signal Input.....	6-14
I Channel Output.....	6-15
V Channel Output	6-16
Miscellaneous I/O Connector	6-17
Appendix D – Auxiliary A/D Input Characteristics	6-19
Overview	6-19
Jumper Identification.....	6-19
Input Impedance Selection.....	6-20
Filter Selection	6-20
Aux A/D Specifications.....	6-20
Comprehensive Index.....	7-1

Chapter 1 -- Introduction

About This Manual

This manual covers the installation and use of the Gamry Instruments' FAS2 Femtostat.

This manual describes use of an FAS2 with Revision 4.2 (and later revisions) of the Gamry Framework software. It is equally useful when setting up a newly purchased potentiostat or modifying the setup of a two year old potentiostat for use with new software.

The bulk of Chapter 1 is an overview of the FAS2's design and modes of operation. Chapter 2 contains FAS2 installation instructions. Chapter 3 describes cell cable connections. Chapter 4 covers the difficult issues of potentiostat stability and approaches to prevent oscillation. Chapter 5 discusses the realities of low current, high impedance measurements.

You will find dry technical material such as specifications and connector pin outs in the Appendices.

This manual does not discuss software installation or operation.

Software support for the FAS2 is described in Gamry's On-line Help system. All the Gamry Instruments' applications that run under the Gamry Framework control the FAS2 via a PSTAT object. See the Framework's On-line Help for information concerning PSTAT objects and their functions.

CE Compliance Required for Sale in Europe

The European Community has instituted standards limiting radio frequency interference from electronic devices and mandating several safety requirements. Gamry Instruments has modified its instruments to comply with these standards. We are shipping CE compliant instruments to all destinations.

The relevant CE regulation is EN 61326.

About the FAS2

The FAS2 Femtostat is a research grade electrochemical instrument optimized for the measurement of very small current signals. It can operate as a potentiostat, a galvanostat, or a ZRA (zero resistance ammeter).

The FAS2 is the low current member of Gamry Instruments' PCI4 Potentiostat family. It shares a number of characteristics with the other members of this family, especially in the areas of signal generation and signal conditioning prior to A/D conversion.

FAS2 features include 10 decade current auto-ranging, electrical isolation from earth ground, and extensive filtering. A sine wave generator on the FAS2 allows its use for impedance measurements at frequencies up to 100 kHz.

The FAS2 consists of a printed circuit card that installs directly into a computer and an external measurement module. The printed circuit card will be referred to as the Controller Card. It requires one unobstructed, full height (11 cm) PCI expansion slots. This slot must be capable of accepting a 26 cm long (10 inch) card. The external module will be referred to as the Potentiostat Module. The cable that connects the Controller Card and the Potentiostat Module uses up a second card slot in the computer.

The Controller Card contains an PCI bus interface, an isolated power supply, a signal generator, and a high performance measurement system.

- The PCI bus interface communicates with the rest of the FAS2 over opto-coupled serial lines. There is no ground connection between the PCI bus circuitry and the analog circuits in the FAS2.
- The isolated DC/DC converter on the Controller Card generates the power used by the Potentiostat Module as well as that used on the Controller Card.
- The standard "DC" signal generator on the Controller Card uses two 16 bit D/A converters. A DDS sine wave generator is packaged on a small "piggyback card" that plugs into the Controller card.
- The Controller Card measurement circuitry includes signal filtering, offset, and switchable gain on two independent measurement channels. The output of these channels is measured using a 16 bit A/D converter.

The Potentiostat Module is a digitally controlled analog potentiostat, with additional galvanostat and ZRA operating modes. Both the current and potential measurement circuits include both a low input current, slow amplifier and a much faster, higher input current amplifier. This allows for both high speed and low current operation using a single instrument.

Femtostat Schematic Diagram

If you are not familiar with electronic schematics or potentiostats, you probably want to skip this section. This information is for expert use only and is not required for routine use of the FAS2 Femtostat.

Figure 1-1 is a highly simplified schematic diagram. It shows the analog portion of the Femtostat in its potentiostatic control mode.

Figure 1-1
FAS2 Analog Circuits in Potentiostat Mode

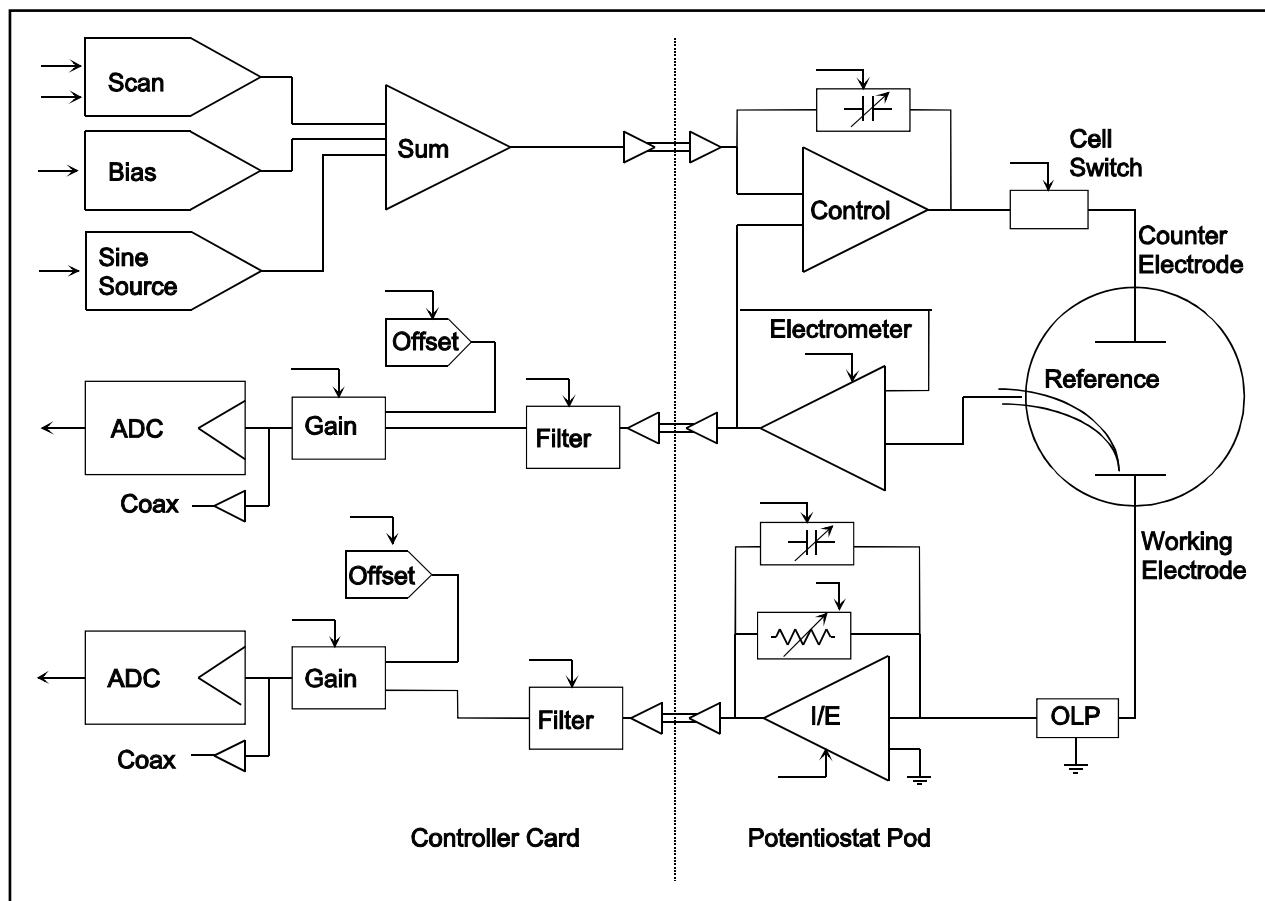

A few points concerning this schematic:

- The circuits on the right side of the schematic are in the Potentiostat Module and those on the left are on the Controller Card. The dotted line shows the separation between the two portions of the instrument. The analog signals sent between the portions are received with differential amplifiers to eliminate grounding problems.
- Arrows pointing into a circuit indicate a computer control input.
- The labels CE , RE and WE stand for counter electrode, reference electrode and working electrode respectively.
- There are two 16 bit D/A converters generating the computer controlled portion of the applied cell voltage.
- The labels F/S on the Electrometer and the I/E converter indicate that the computer can switch these amplifiers between a fast and a slow configuration.
- The I/E converter feedback resistor consists of 9 decade resistors that can be switched in under computer control.
- The cell switch is actually two switches in series - a relay for low leakage and an FET switch for fast response.
- The label OLP refers to overload protection.
- Gains and resistor values are not shown.
- Two capacitors can be switched across the I/E converter resistor. These capacitors are used for filtering and stability compensation.
- The control amplifier is shown at the upper right side of the schematic. Compensation capacitors can be switched across the control amplifier to adjust its bandwidth and improve potentiostat stability.
- The A/D converter is a 16 bit successive approximation type converter.
- Some analog circuits, including over-load detection circuitry, positive feedback IR compensation, the auxiliary D/A converter, power circuits, and data acquisition controls are not shown.
- All digital circuits, including the AT bus interface, timers, state machines, opto-couplers, and digital I/O are not shown.
- Timing for both data acquisition and D/A update in the signal generator is controlled by a state machine working with a crystal oscillator generated clock. A busy micro-processor in the computer cannot create timing jitter.

Notational Conventions

In order to make this manual more readable we have adopted some notational conventions. These are used throughout this manual and all other Gamry Instruments manuals.

- Numbered lists. A numbered list is reserved for step by step procedures, with the steps always performed sequentially.
- Bulleted List. The items in a bulleted list, such as this one, are grouped together because they represent similar items. The order of items in the list is not critical.
- Hexadecimal numbers. Hexadecimal numbers are used for hardware related items such as addresses. The Gamry Framework and this manual uses the C programming language convention: all hexadecimal numbers have a prefix of 0x.
- File names and directories. Inside paragraphs, references to computer files and directories will be in quotes, for example: "WIN.INI" and "WFRAMEWORKWFRAMEWORK.EXE".

Chapter 2 -- Installation

An FAS2 Femtostat is only useful after it has been installed in an AT compatible computer.

If you purchase an FAS2 in a system that includes both a computer and an applications software package, Gamry Instruments, Inc. will install the FAS2 (and the system software) to produce a "turn-key" system. You may ignore this chapter if you have purchased a turn-key system.

If you buy your own computer, ~~you are adding~~ an FAS2 to an existing system, or ~~you are moving~~ an old FAS2 to a new computer, you need to know how to install an FAS2 into a computer. Read on.

Software installation is discussed in the [Operator's Installation](#) Manual for each software package. It will not be discussed here.

Computer Requirements

Before you install an FAS2 into your own computer you must make sure that your computer meets these simple requirements.

- A computer based on one of the Pentium™ family of [Intel](#) microprocessors or a 100% compatible processor from another vendor.
- One unobstructed, full height (11 cm) PCI expansion slots [for each](#) FAS2 in the system. Each slot must be capable of accepting a 26 cm long (10 inch) card.
- A second slot which is used up by the mini-panel and cable that connects the Controller Card and the Potentiostat Module. This slot does not need to be PCI compatible, full length or full height.
- Up to 40 watts of power supply capacity for each FAS2. This is in addition to the power normally drawn by your computer and its standard peripherals.
- One unused disk drive power connector. This connector is used to power the PCI4 Controller Card that is an essential component in the FAS2 system.

Most of the PCI4's power is drawn from the computer's +12 volt and +5 volt supplies. However, the PCI4 also requires a small amount (< 50 mA) of current taken from the computer's -12 volt supply.

Gamry's Windows applications software packages may impose additional, more stringent requirements.

PCI Compatibility

The PCI4 has been designed for compatibility with Revision 2.2 of the PCI Specification. As described in that specification, it is a universal card, able to operate with either 3.3 volt and 5.0 volt PCI signaling levels.

The PCI4 does not draw power from the 3.3 volt supply pins on the PCI bus connector. It can therefore operate with older computers that did not provide 3.3 volts on the PCI bus. It should operate with all PCI computers compliant with Revision 2.0 and higher of the PCI Specification.

Positional Conventions

Throughout this manual, reference will be made to positions on the PCI4 Controller Board. In order to avoid confusion, we will define some conventions that describe positions on this card.

Assume:

- The Controller Card is lying on a table in front of you.
- The component side of the card is up.
- The card edge (where the card plugs into the computer) is facing you.

Under these assumptions, Figure 2-1 illustrates our positional convention.

Figure 2-1
Positional Conventions



Handling the FAS2 Controller Card

The FAS2 Controller Card, like most electronic components, is susceptible to damage from static discharges and connection to live circuits. Some elementary precautions should be taken when handling and installing these cards.

- The Controller Card is shipped in an anti-static bag. Leave the card in its bag until you need to install or reconfigure it.
- Always turn off your computer before plugging in the card.
- If you need to leave the card out of its anti-static bag, lay the anti-static bag on a flat surface, then lay the card on top of the bag.
- Prior to handling the card, you should momentarily ground yourself to eliminate any static charges on your body. A good way to accomplish this is to turn off your computer, then lightly touch your finger to an unpainted portion of the computer's metal chassis.
- Save the anti-static bag. You must use it if the card is shipped while not installed in a computer. This includes occasions when the card must be returned to Gamry Instruments, Inc. for repair.

Multiple Potentiostat Systems

Gamry's current Framework software (Revision 4.2) allows a computer to operate several Gamry Instruments potentiostats simultaneously. These can include FAS2s, PCI4s, and older PC4 family devices in the same computer. Contact our home office or your local sales representative if you need assistance configuring a system contain both PCI4 and PC4 family hardware.

Gamry's Framework contains a utility script to identify PCI4 Family potentiostats in a multiple potentiostat system. See the Getting Started guide for instructions concerning the use of this program.

Plug & Play System Configuration

The PCI4 Controller Card is completely compatible with the Windows Plug & Play configuration system. Unlike Gamry's older potentiostats, you don't need DIP switches to configure the card. Like most Plug & Play hardware, it is best if you install the software for the FAS2 before you install the potentiostat hardware.

A Setup program will normally startup automatically when you place the Gamry Instrument's Software CD into the CD drive on your computer. Consult Gamry's software installation manual if you need assistance accessing the Setup program or choosing options in its menus.

Installing the Controller Card in Your Computer

NOTE: Please review the discussion on **Handling the FAS2 Controller Card** earlier in this chapter prior to proceeding.

The following procedure is used to install an FAS2 Controller Card in your computer. It assumes that you are using the default configuration for the installed card or that you have already configured the card for a non-standard configuration.

1. Turn off your computer.
2. Following your computer manufacturer's instructions, open up the computer to expose its expansion card slots.
3. Locate an empty expansion slot that has a PCI interface. The slot must be at least 26 cm long..

If necessary, remove the retaining screw and slot cover (the 'L' shaped metal bracket). Save the screw for use later.

4. Locate a second empty slot that is within 20 cm of the first. You may have to move some of your existing cards to get two suitable slots. Again, remove the retaining screw and slot cover, saving the screw for use later.
5. Remove the Controller Card from its anti-static bag.
6. Plug the Controller Card into the slot with a PCI interface. Make sure the card seats securely in the edge card connector on the motherboard. Secure the card in the slot using the screw from Step 3.
7. Locate the Potentiostat Connector Mounting Bracket. It is a metal L shaped bracket with a D connector and cable mounted on it. Place this bracket in the card slot identified in Step 4. Secure the bracket using the screw from Step 4.

This bracket is used to interconnect the Controller Card and the Potentiostat module.

8. Do not close up the computer yet.

Connecting the FAS2 Interconnection Cable to the Controller Card

The cable on the L bracket that you just added to the computer is connected to the Controller Card as follows:

1. Locate the 26 pin header (group of 26 pins) on the Controller Card. It is in the upper middle of the card.
2. Notice that one pin is missing from this header. This missing pin is used to "key" the connector and prevent incorrect cable installation.
3. Look at the 26 pin connector on the cable attached to the Potentiostat Connector Mounting Bracket. One of the 26 holes in this connector has been blocked.
4. Plug the connector into the 26 pin header. The blocked hole must line up with the missing pin on the header. If they do not line up, you will be unable to adequately seat the connector on the header.
5. Locate the power input connector on the upper left side on the Controller card. This mates with a "disk drive" power cable from the PC's power supply. Locate an unused power cable and connect it to the Controller card's power input connector. A power cable extender was supplied with the FAS2, in case the computer's disk drive power cable is too short.

Note that the power cables can only mate in one direction. If the power cable will not plug into the card, rotate the cable 180°.

6. Carefully double check your work.
7. CAUTION: The connector keying does not prevent one type of connector misalignment. You can easily miss an entire row of pins. Make sure that both rows of pins are in the connector.
8. Once this step is completed you may close up the computer.

Connecting the Potentiostat Module to the Controller Card

Turn off your computer before making this connection.

The cable used to make this connection is provided with the FAS2. ~~It should be marked with its Gamry Instruments' part number, 985-00028.~~ There is a 25 pin D connector on both ends of the cable.

The female end of this cable connects to the male 25 pin D connector on the Potentiostat Connector Mounting Bracket.

CAUTION: Many older computers include an XT compatible COM port that also uses a male 25 pin D connector. If your computer has two or more male 25 pin D connectors, make sure that you have connected to the correct one. Plugging the Potentiostat Module into a COM port could damage the Potentiostat Module or the computer.

The male end of the cable connects to the Potentiostat Module.

CAUTION: You must tighten the mounting screws that hold both connectors in place. Circuitry in the FAS2 could be damaged if this cable is accidentally unplugged while the computer is powered.

Application Software Installation and System Checkout

Software installation is slightly different for each Gamry Instruments, Inc. application package. Refer to the software installation instructions in the [Operator's Installation](#) Manual for each application package in your system.

You should also perform the system checkout procedures for each application. Follow the instructions in each application's [Operator's Installation](#) Manual. The system checkout procedures check for correct hardware and software installation. They are not a comprehensive test of each facet of system operation.

Calibration

After you have run the system checkout procedure(s), you should calibrate each FAS2 Femtostat installed in your system. A calibration script is provided with the Gamry Framework. The [Operator's Installation](#) Manual for every major application package contains instructions for calibration using this script.

CAUTION: FAS2calibration calls for an external resistive dummy cell. FAS2s are provided with a Universal Dummy Cell, which includes a 2 k Ω 0.05% accurate resistor in the position marked "Calibration". After calibration, please place this dummy cell in a safe place where you can find it if your unit requires recalibration.

Its wattage is unimportant. Some performance checks in the calibration process may fail if the resistors inaccuracy exceeds 0.1% (2 Ohms).

Potentiostat calibration is only required infrequently. You should recalibrate under the following circumstances:

- You are installing an FAS2 Femtostat into a new computer or moving an FAS2 into a different computer. The FAS2 should be calibrated in the new machine.
- It has been about one year since your last calibration.
- Your potentiostat has been serviced.
- You notice breaks or discontinuities in the data curves recorded with your system.
- You have lost or replaced your "GAMRY.INI" file.

Chapter 3 -- Cell Lead Connections

Cell Indicator

The FAS2 is equipped with one LED indicator, located on the FAS2 pod's front panel. This yellow LED functions as a Cell Indication. It lights whenever the FAS2 cell switch is on and goes dark whenever the cell is at open circuit.

The Cell Indicator is also used in the identification of potentiostats in a multiple potentiostat system, using a special "Identify Potentiostats" script. Appendix C of Gamry's *Getting Started Guide* describes the use of this script.

Cell Connections

Every FAS2 Femtostat is shipped with four cables used to connect the Potentiostat Module to an electrochemical cell. All operating modes – potentiostatic, galvanostatic and ZRA – use the same connections.

Working Electrode

The Working Electrode cable has an SMC coaxial connector on one end and a green banana plug on the other end. The cable is shipped with an alligator clip covering the banana plug.

The SMC connector screws into the Working connector on the Potentiostat module front panel. The banana plug end connects to the working electrode of an electrochemical cell. The working electrode is the specimen being tested.

In the potentiostat and ZRA modes this lead is the input to a virtual ground type current to voltage converter. In galvanostat mode, it is the virtual ground terminal of an op amp galvanostat. The potential at this point is thus kept near to FAS2's floating ground.

Reference Electrode

The Reference Electrode cable has an SMC coaxial connector on one end and a white pin jack on the other end. The cable is shipped with an alligator clip plugged into the pin jack.

The SMC connector screws into the Reference connector on the Potentiostat module front panel. The pin jack end connects to the reference electrode of an electrochemical cell.

This lead is usually connected to a standard reference electrode such as an SCE or Ag/AgCl electrode. In all operating modes, this lead is the input to a high input impedance electrometer. With the working electrode at a virtual ground, the output of this electrometer is the reference electrode potential versus the working electrode.

Counter Electrode

The Counter Electrode cable has an SMC coaxial connector on one end and a red banana plug on the other end. The cable is shipped with an alligator clip covering the banana plug.

The SMC connector screws into the Counter connector on the Potentiostat module front panel. The banana plug end connects to the counter electrode of an electrochemical cell.

The counter electrode (often called the auxiliary electrode) is usually a large inert metal or graphite electrode. The counter electrode terminal is the output of the FAS2's ± 30 mA at ± 12 volt control amplifier.

Ground Connection

The FAS2 is shipped with a ground lead suitable for most applications. One end connects to the Ground connector on the FAS2 front panel. The other end is equipped with a black alligator clip.

The ground connector on the FAS2's front panel is connected to the FAS2's Floating Ground. This is the circuitry ground for the analog circuits in the FAS2.

When the FAS2 is used with a cell that is earth grounded, this terminal should be left disconnected. Earth grounded cells include most stress apparatus, autoclaves, and pipeline probes. In a typical pipeline probe, none of the electrodes (working, counter and reference) are connected to earth ground directly. However, the pipeline wall is effectively a fourth electrode which is earth grounded.

If your cell is a typical glass laboratory cell, all of the electrodes are isolated from earth ground. In this case, you may be able to reduce noise in your data by connecting the FAS2's Floating Ground to a source of earth ground. A water pipe is often a suitable source of ground.

Caution: If any electrode is at earth ground, you must not connect the Floating Ground to earth. As mentioned above, autoclaves, stress apparatus, and field measurements often involve earth grounded electrodes.

Chapter 3 -- Cell Lead Connections -- Cell Connections

Whenever you measure very small currents, you will need a metal enclosure completely surrounding your cell (a Faraday shield). This shield significantly lowers the current noise. The Faraday shield should be connected to the FAS2's Floating Ground. If your electrodes are all isolated from ground, you may also connect the shield to a source of earth ground.

Chapter 4 -- Stability in Potentiostat Mode

Capacitive Cells and Stability

All potentiostats can become unstable when connected to capacitive cells. The capacitive cell adds phase shift to the potentiostat's already phase shifted feedback signal. The additional phase shift can convert the potentiostat's power amplifier into a power oscillator.

To make matters worse, almost all electrochemical cells are capacitive.

Potentiostat oscillation is an AC phenomenon. However, it can affect both AC and DC measurements. Oscillation often causes excessive noise or sharp DC shifts in the system's graphical output. The FAS2 Femtostat's potentiostat is often stable on less sensitive current ranges and unstable on more sensitive current ranges. Whenever you see sharp breaks in the current recorded on the system, you should suspect oscillation.

The FAS2 has been tested for stability with cell capacitors between 10 pF and 1 F. In all but its fastest [control amp](#) speed setting, it is stable on any capacitor in this range -- as long as the impedance in the reference electrode lead does not exceed 20 k Ω . With reference electrode impedances greater than 20 k Ω , the FAS2 may oscillate. The RC filter formed by the reference electrode impedance and the reference terminal's input capacitance filters out the high frequency feedback needed for potentiostat stability.

Longer cell cables make the problem worse by increasing the reference terminal's effective input capacitance.

Even when the system is stable (not oscillating), it may exhibit ringing whenever there is a voltage step applied to the cell. The FAS2's D/A converters routinely apply steps, even when making a pseudo-linear ramp. While this ringing is not a problem with slow DC measurements, it can interfere with faster measurements. The steps taken to eliminate potentiostat oscillation also help to minimize ringing.

Improving Potentiostat Stability

There are a number of things that you can do to improve an unstable or marginally stable FAS2 potentiostat/cell system. This list is not in any particular order. Any or all of these steps may help.

- Slow down the potentiostat. The FAS2 has 4 control amplifier speed settings, which can be selected in software. Slower settings are generally more stable.
- Increase the FAS2's I/E stability setting. The FAS2 includes 2 capacitors that can be paralleled with its I/E converter resistors. These capacitors are connected to relays that are under software control. Contact your local Gamry Instruments' representative for more information concerning changes in these settings.
- Lower the reference electrode impedance. Make sure that you don't have a clogged reference electrode junction. Avoid asbestos fiber reference electrodes and double junction electrodes. Avoid small diameter Lugin capillaries. If you do have a Lugin capillary, make sure that the capillaries' contents are as conductive as possible.
- Add a capacitively coupled low impedance reference element in parallel with your existing reference electrode. The classic fast combination reference electrode is a platinum wire and a junction isolated SCE. See Figure 4-1. The capacitor insures that DC potential comes from the SCE and AC potential from the platinum wire. The capacitor value is generally determined by trial and error.

Figure 4-1
Fast Combination Reference Electrode

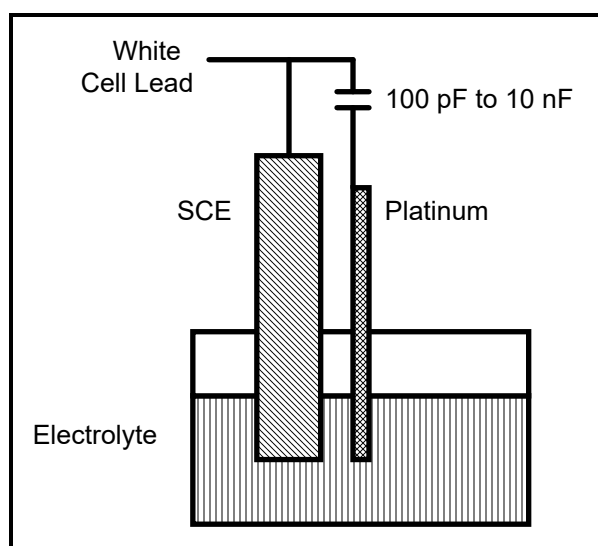

- Provide a high frequency shunt around the cell. A small capacitor between the red and white cell leads allows high frequency feedback to bypass the cell. See Figure 4-2. The capacitor value is generally determined by trial and error. One nanofarad is a good starting point.

In a sense, this is another form of an AC coupled low impedance reference electrode. The counter electrode is the low impedance electrode, eliminating the need for an additional electrode in the solution.

Figure 4-2
High Frequency Shunt

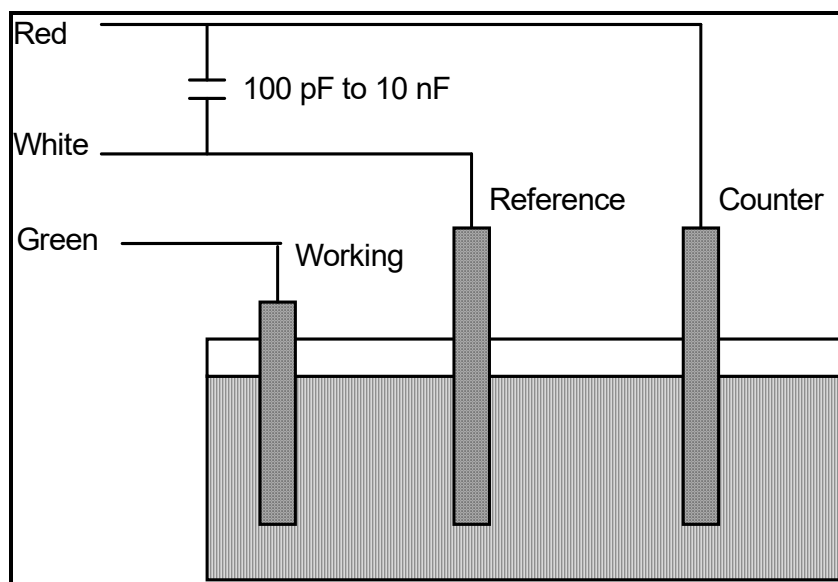

- Add resistance to the counter electrode lead. See Figure 4-3. This change lowers the effective gain bandwidth product of the control amplifier. As a rule of thumb, the resistor should be selected to give one volt of drop at the highest current expected in the test being run. For example, if you expect your highest current to be around 1 mA, you can add a 1 k Ω resistor.

This resistor has no effect on the DC accuracy of the potentiostat. It can create problems in high speed experiments such as fast CV scans or EIS, which need high bandwidth.

Figure 4-3
Resistor Added for Stability

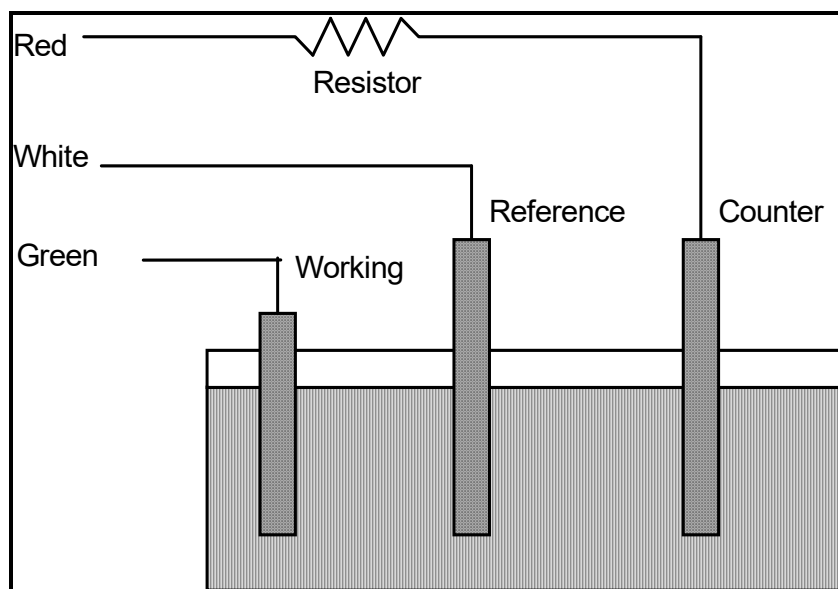

Chapter 5 -- Measurement of Small Signals

Overview

The FAS2 operates near the limits of measurement science. It can resolve current changes as small as 1 femtoamp ~~to~~ (10^{-15} amps). To place this current in ~~prospective perspective,~~ 1 fA represents the flow of about 6000 electrons per second!

The small currents measured by the FAS2 place demands on the instrument, the cell, the cables and the experimenter. Many of the techniques used in higher current electrochemistry must be modified when used to measure pA and fA currents. In many cases, the basic physics of the measurement must be considered.

This chapter will discuss the limiting factors controlling low current measurements. It will include hints on cell and system design. The emphasis will be on EIS (Electrochemical Impedance Spectroscopy), a major application for the FAS2.

Measurement System Model and Physical Limitations

To get a feel for the physical limits implied by femtoamp measurements, consider the equivalent circuit shown in Figure 5-1. We are attempting to measure a cell impedance given by Z_{cell} .

This model is valid for analysis purposes even though the real FAS2 circuit topology differs significantly.

In Figure 5-1:

E_s	Is an ideal signal source
Z_{cell}	Is the unknown cell impedance
R_m	Is the current measurement circuit's current measurement resistance
R_{shunt}	Is an unwanted resistance across the cell
C_{shunt}	Is an unwanted capacitance across the cell
C_{in}	Is the current measurement circuit's stray input capacitance
R_{in}	Is the current measurement circuit's stray input resistance
I_{in}	Is the measurement circuit's input current

In the ideal current measurement circuit R_{in} is infinite while C_{in} and I_{in} are zero. All the cell current, Z_{cell} , flows through R_m .

With an ideal cell and voltage source, R_{shunt} is infinite and C_{shunt} is zero. All the current flowing into the current measurement circuit is due to Z_{cell} .

The voltage developed across R_m is measured by the meter as V_m . Given the idealities discussed above, one can use Kirchoff's and Ohms law to calculate Z_{cell} :

$$Z_{cell} = E_s * R_m / V_m$$

Figure 5-1
Equivalent Measurement Circuit

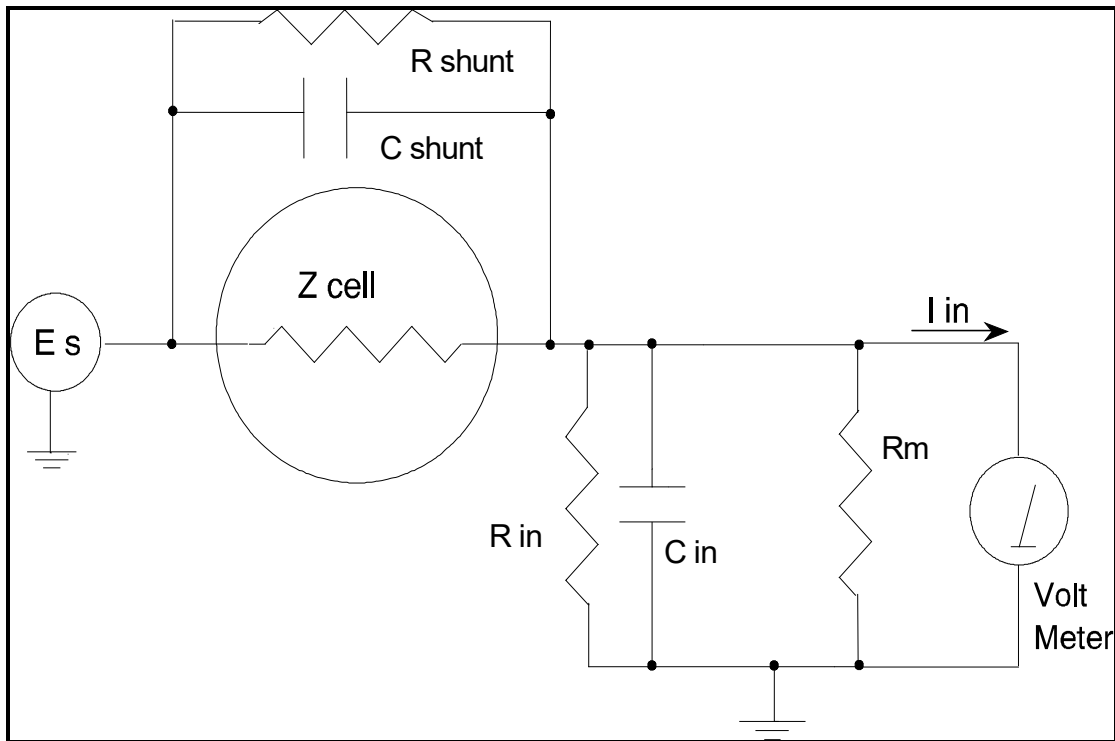

Unfortunately technology limits high impedance measurements because of:

- Current measurement circuits always have non-zero input capacitance, i.e. $C_{in} > 0$
- Infinite R_{in} cannot be achieved with real circuits and materials
- Amplifiers used in the meter have input currents, i.e. $I_{in} > 0$
- The cell and the potentiostat create both a non-zero C_{shunt} and a finite R_{shunt}

Additionally, basic physics limits high impedance measurements via Johnson noise, which is the inherent noise in a resistance.

Johnson Noise in Z_{cell}

Johnson noise across a resistor represents a fundamental physical limitation. Resistors, regardless of composition, demonstrate a minimum noise for both current and voltage, per the following equation.

$$E = (4 k T R \delta F)^{1/2}$$

$$I = (4 k T \delta F / R)^{1/2}$$

where:

k = Boltzman's constant 1.38×10^{-23} J/°K

T = temperature in °K

δF = noise bandwidth in Hz

R = resistance in ohms.

For purposes of approximation, the Noise bandwidth, δF , is equal to the measurement frequency. Assume a 10^{12} ohm resistor as Z_{cell} . At 300-°K and a measurement frequency of 1 Hz this gives a voltage noise of 129 μV rms. The peak to peak noise is about 5 times the rms noise. Under these conditions, you cannot make a voltage measurement of ± 10 mV across Z_{cell} without an error of up to $\pm 3\%$. Fortunately, an AC measurement can reduce the bandwidth by integrating the measured value at the expense of additional measurement time. With a noise bandwidth of 1 mHz, the voltage noise falls to 4 μV rms.

Current noise on the same resistor under the same conditions is 0.129 fA. To place this number in perspective, a ± 10 mV signal across this same resistor will generate a current of ± 10 fA, or again an error of up to $\pm 3\%$. Again, reducing the bandwidth helps. At a noise bandwidth of 1 mHz, the current noise falls to 0.004 fA.

With E_s at 10 mV, an EIS system that measures 10^{12} ohms at 1mHz is about 3 decades away from the Johnson noise limits. At 0.1 Hz, the system is close enough to the Johnson noise limits to make accurate measurements impossible. Between these limits, readings get progressively less accurate as the frequency increases.

In practice, EIS measurements usually cannot be made at high enough frequencies that Johnson noise is the dominant noise source. If Johnson noise is a problem, averaging reduces the noise bandwidth, thereby reducing the noise at a cost of lengthening the experiment.

Finite Input Capacitance

C_{in} in Figure 5-1 represents unavoidable capacitances that always arise in real circuits. C_{in} shunts R_m , draining off higher frequency signals, limiting the bandwidth that can be achieved for a given value of R_m . This calculation shows at which frequencies the effect becomes significant. The frequency limit of a current measurement (defined by the frequency where the phase error hits 45°) can be calculated from:

$$f_{\text{RC}} = 1 / (2 \omega R_m C_{\text{in}})$$

Decreasing R_m increases this frequency. However, large R_m values are desirable to minimize voltage drift and voltage noise.

A reasonable value for C_{in} in a practical, computer controllable low current measurement circuit is 5 pF. For a 30 pA full scale current range, a practical estimate for R_m is 10^{10} ohms.

$$f_{RC} = 1 / 6.28 (1 \times 10^{10}) (5 \times 10^{-12}) \approx 3 \text{ Hz}$$

In general, one should stay two decades below f_{RC} to keep phase shift below one degree. The uncorrected upper frequency limit on a 30 pA range is therefore around 30 mHz.

One can measure higher frequencies using the higher current ranges (i.e. lower impedance ranges) but this would reduce the total available signal below the resolution limits of the "voltmeter". This then forms one basis of statement that high frequency and high impedance measurements are mutually exclusive.

Software correction of the measured response can also be used to improve the useable bandwidth, but not by more than an order of magnitude in frequency.

Leakage Currents and Input Impedance

In Figure 5-1, both R_{in} and I_{in} affect the accuracy of current measurements. The magnitude error due to R_{in} is calculated by:

$$\text{Error} = 1 - R_{in} / (R_m + R_{in})$$

For an R_m of 10^{10} ohms, an error < 1% demands that R_{in} must be > 10^{12} ohms. PC board leakage, relay leakage, and measurement device characteristics lower R_{in} below the desired value of infinity.

A similar problem is the finite input leakage current I_{in} into the voltage measuring circuit. It can be leakage directly into the input of the voltage meter, or leakage from a voltage source (such as a power supply) through an insulation resistance into the input. If an insulator connected to the input has a 10^{12} ohm resistance between +15 volts and the input, the leakage current is 15 pA. Fortunately, most sources of leakage current are DC and can be tuned out in impedance measurements. As a rule of thumb, the DC leakage should not exceed the measured signal by more than a factor of 10.

The FAS2 uses an input amplifier with an input current of around 50 fA. Other circuit components may also contribute leakage currents. You therefore cannot make absolute current measurements of low fA currents with the FAS2. In practice, the input current is approximately constant, so current differences or AC current levels of a few fA can be measured.

Voltage Noise and DC Measurements

Often the current signal measured by a potentiostat shows noise that is not the fault of the current measurement circuit's fault. This is especially true when you are making DC measurements. The cause of the current noise is noise in the voltage applied to the cell.

Assume that you have a working electrode with a capacitance of 1 μF . This could represent a passive layer on a metal specimen. The impedance of this electrode, assuming ideal capacitive behavior, is given by

$$Z = 1/j\omega C$$

At sixty Hertz, the impedance value is about 2.5 $\text{k}\Omega$.

Apply an ideal DC potential across this ideal capacitor and you get no DC current.

Unfortunately, all potentiostats have noise in the applied voltage. This noise comes from the instrument itself and from external sources. In many cases, the predominant noise frequency is the AC power line frequency.

Assume a reasonable noise voltage, V_n , of 10 μV . Further, assume that this noise voltage is at the US power line frequency of 60 Hz. It will create a current across the cell capacitance:

$$I = V_n/Z \approx 4 \text{ nA}$$

This rather large noise current will prevent accurate DC current measurement in the pA ranges.

In an Electrochemical Impedance measurement, you apply an AC excitation voltage that is much bigger than the typical noise voltage, so this is not a factor.

Shunt Resistance and Capacitance

Non-ideal shunt resistance and capacitance arises in both the cell and the potentiostat. Both can cause significant measurement errors.

Parallel metal surfaces form a capacitor. The capacitance rises as either metal area increases and as the separation distance between the metals decreases.

Wire and electrode placement have a large effect on shunt capacitance. If the clip leads connecting to the working and reference electrodes are close together, they can form a significant shunt capacitor. Values of 10 pF are common. This shunt capacitance cannot be distinguished from "real" capacitance in the cell. If you are measuring a paint film with a 30 pF capacitance, 10 pF of shunt capacitance is a very significant error.

Shunt resistance in the cell arises because of imperfect insulators. No material is a perfect insulator (one with infinite resistance). Even PTFE, which is one of the best insulators known, has a bulk resistivity of about 10^{14} ohms. Worse yet, surface contamination often lowers the effective resistivity of good insulators. Water films can be a real problem, especially on glass.

Shunt capacitance and resistance also occur in the potentiostat itself. The FAS2 Potentiostat Mode specifications in Appendix A contain equivalent values for the potentiostat's R_{shunt} and C_{shunt} . These values can be measured by an impedance measurement with no cell.

In most cases, the cell's shunt resistance and capacitance errors are larger than those from the potentiostat.

Hints for System and Cell Design

The following hints may prove helpful.

Faraday Shield

A Faraday shield surrounding your cell is mandatory for very low level measurements. It reduces both current noise picked up directly on the working electrode and voltage noise picked up by the reference electrode.

A Faraday shield is a conductive enclosure that surrounds the cell. The shield can be constructed from sheet metal, fine mesh wire screen, or even conductive plastic. It must be continuous and completely surround the cell. Don't forget the areas above and below the cell. All parts of the shield must be electrically connected.

If possible, place the FAS2 potentiostat module within the Faraday shield. Your computer should be kept outside of the shield. The opening in the shield should be just slightly larger than the cable between the computer and FAS2 potentiostat module.

The shield must be electrically connected to the FAS2's ground terminal.

An additional connection of both the shield and the FAS2 ground to an earth ground may also prove helpful.

NOTE: Only connect the FAS2 ground to earth ground if all conductive cell components are well isolated from earth ground. A glass cell is usually well isolated. An autoclave is generally not well isolated.

Avoid External Noise Sources

Try to keep your system away from electrical noise sources. Some of the worst are:

- Fluorescent lights
- Motors
- Radio transmitters
- Computers and computer monitors

Try to avoid AC powered or computerized apparatus within your Faraday shield. The one exception is the FAS2 potentiostat module itself.

Cell Lead Length and Construction

The FAS2 has three true cell leads. They are the leads for the Working Electrode, Reference Electrode, and Counter Electrode. The cell leads connect to the FAS2 potentiostat module via SMC miniature coaxial connectors.

The cell leads are made from coaxial cable with a virgin PTFE dielectric.

The FAS2 is shipped with short cell leads. Use of longer cell leads may cause significant problems. These include potentiostat oscillation, loss of bandwidth, EIS phase shifts and additional noise.

The FAS2 cell leads are also built for very good isolation between the inner conductor and the shield. Both commercial and home built SMC cables are unlikely to offer as good an isolation resistance.

None of the above discussion applies to the Ground connection of the FAS2. In most cases, any type of cable may be used in this connector. Lead length is generally not a problem. The only exception occurs in floating operation on an earth grounded cell, where any connections made to the ground terminal should be very well insulated from earth ground. PTFE insulated wire is preferred if a connection to the ground is required at all when floating.

Lead Placement

Many experiments with the FAS2 involve cells with very small capacitances, the value of which may be important.

In these cases, the capacitance between the FAS2's leads can result in an error. The FAS2 alligator clips can have 10 pF or more of mutual capacitance if they are run alongside each other.

If you wish to avoid excessive capacitance.

- Place the leads as far apart as possible. Pay special attention to the working electrode lead.
- Have the leads approach the cell from different directions.
- Remove the alligator clips from the leads. In extreme cases you can replace the banana plugs and pin jack with smaller connectors. If you do so, be careful not to compromise the center conductor to shield isolation.

The cell leads must not be moved during an experiment which measures small currents. Both microphonic and triboelectric effects can create spurious results when the cell cables are moved.

Cell Construction

If you need to measure small currents or high impedances, make sure that your cell construction does not limit your response.

A cell where the resistance between the electrodes is only 10^{10} ohms cannot be used to measure 10^{13} ohm impedances. In general, glass and PTFE are the preferred cell construction materials. Even glass may be a problem if it is wet.

You also must worry about C_{shunt} . Make the "inactive" portion of your electrodes as small as possible. Avoid placing electrodes close together or parallel with each other.

Reference Electrode

Keep your reference electrode impedance as low as possible. High impedance reference electrodes can cause potentiostat instability and excessive voltage noise pickup.

Try to avoid:

- Narrow bore or Vycor tipped Lugin capillaries.
- Poorly conductive solutions - especially in Lugin capillaries.
- Asbestos thread and double junction reference electrodes.

Instrument Settings

There are several things to remember in setting up a very sensitive experiment.

- In EIS, use the largest practical excitation. Don't use a 10 mV excitation on a coated specimen that can handle 100 mV without damage.
- Avoid potentials where large DC currents flow. You cannot measure 1pA of AC current on top of 1 mA of DC current.

EIS Speed

In EIS, do not expect the FAS2 to measure 10^{12} ohm impedances at 1 kHz. Many of the factors listed above limit the performance.

As a rule of thumb, the product of Impedance, Z , times frequency, f , must be less than 10^{10} ΩHz for good EIS measurements with an FAS2.

$$Z \cdot f < 10^{10} \Omega\text{Hz}$$

Ancillary Apparatus

Do not use the FAS2 with ancillary apparatus connected directly to any of the cell leads. Ammeters and voltmeters, regardless of their specifications, almost always create problems when connected to the FAS2 cell leads.

Floating Operation

The FAS2 is capable of operation with cell:s where one of the electrodes or a cell surface is at earth ground. Examples of earth grounded cells include: autoclaves, stress apparatus, pipelines, storage tanks and battleships. The FAS2's internal ground is allowed to float with respect to earth ground when it works with these cells, hence the name floating operation.

Instrument performance can be substantially degraded when the FAS2 is operated in a floating mode. The instrument specifications only apply on isolated cells with the FAS2 earth ground referenced (not floating).

Special precautions must be taken with the cell connections when the FAS2 must float. Make sure that all the cell connections are isolated from earth ground. In this case, even the Ground terminal of the FAS2 must be kept isolated.

The case of the FAS2 must also be isolated from earth ground. Do not set the FAS2 potentiostat module down on a wet dirt surface and expect good floating measurements.

Finally, most ancillary apparatus connected to the cell of the FAS2 must be isolated. External voltmeters, ammeters, FRA's etc. must be isolated. This includes devices connected to the monitor connectors located on the FAS2 controller board minipanel.

Appendix A -- Specifications

Control Amplifier

Compliance Voltage	± 12 volts @ 30 mA
Output Current	± 30 mA
Unity Gain Bandwidth (software selectable)	>1 MHz, > 200 kHz, > 20 kHz
Slew Rate	>8 V/ μ sec

Electrometer - Fast Mode

Input Impedance	> 10 G Ω in parallel with 20 pF
Input Current	< 50 pA
Bandwidth (-3dB)	> 5 MHz

Electrometer - Slow Mode

Input Impedance	> 1 T Ω in parallel with 8 pF
Input Current	< 100 fA
Bandwidth (-3dB)	> 250 kHz

Voltage Measurement

Full Scale Ranges	± 30 V (± 12 V usable), ± 3 V, ± 300 mV, ± 30 mV
Resolution	16 Bits
DC Accuracy	$\pm 0.2\%$ Range ± 1 mV
Offset Range	± 12 V with 1.5 mV resolution

Current Measurement - All

Analog Full Scale Ranges	± 30 pA to ± 30 mA in decades
Controller Board Gains	1, 10, 100
Resolution	16 bits
Offset Range	± 4 X full scale (only 2X full scale is useful)

Current Measurement - High Speed

DC Accuracy	$\pm 0.2\%$ range $\pm 1\text{nA}$
Bandwidth (-3 dB)	1 MHz (30 μA --30mA)
	100 kHz (3 μA)
	100 Hz (300 pA)

Current Measurement - Low Speed

DC Accuracy	$\pm 0.2\%$ range ± 1 pA
Bandwidth (-3 dB)	250 kHz (30 μ A--30mA)
	25 kHz (3 μ A)
	10 Hz (30 pA)

Auxiliary A/D Input (see Appendix D)

Range	± 3 volts differential
Bandwidth	20 Hz
Input Impedance	100 k Ω

Auxiliary D/A Output

Range	± 5 volts or 0 to 10 volts
Resolution	2.5 mV

Environmental

Operating Temperature	0-70 $^{\circ}$ C (inside computer)
Specification Temperature	25 $^{\circ}$ C

Potentiostat Mode - All

Applied E Range	± 11 volts
Accuracy	± 2 mV $\pm 0.3\%$ of setting
DC Bias	± 8 V
Scan Ranges	± 6.4 V, ± 1.6 V, and ± 0.4 V
Resolution	200 μ V/bit, 50 μ V/bit, 12.5 μ V/bit
Drift	< 30 μ V/C
Noise and Ripple	< 20 μ V rms (1Hz - 10 kHz)
Equivalent Cell Shunt - Resistance	> 2 x10 ¹³ Ω
Equivalent Cell Shunt - Capacitance	< 500 fF

Galvanostat Mode

Applied i range	\pm full scale current (no 30 pA range)
DC accuracy	$\pm 0.3\%$ full scale
Scan Ranges	± 2 X full scale current

Current Interrupt

Measurement Type	(sample 2 points on decay, extrapolate)
Cell Switching Time	< 1 μ sec (1 k Ω cell)
Minimum Interrupt Time	15 μ sec
Maximum Interrupt Time	64 msec

A/D converter

Resolution	16 bits
Accuracy	0.1% of full scale
Timing	50 μ sec to 600 sec

I/O Connections

Analog Outputs	Voltage, Potential
External Input (added to Applied E or I)	10 k Ω input Z
Digital	4 inputs, 4 outputs

Other

Power	20 W maximum < 1.4A at 12 volts < 300 mA at +5 V < 20 mA at -12 V
Leakage i (floating, earthed Working Electrode)	< 5 pA @ DC

NOTES:

1. All specifications subject to change without notice
2. Offset specifications apply after software calibration

Appendix B -- Changing The Default FAS2 Settings

Overview

Your FAS2 Potentiostat is fully compliant with the Windows Plug & Play system. FAS2 resources (interrupt settings, register addresses) are not assigned hardware switches or jumpers. Instead, the Windows Device Manager chooses resource assignments. The settings chosen by the Device Manager can be reviewed by selecting Windows Control Panel, Device Manager from the Windows Start Menu.

The Gamry Framework still requires a "GAMRY.INI" file. This file is used to name the potentiostats in the system. This file is also used to store hardware configuration information for older ISA based Gamry hardware.

Turnkey systems are configured appropriately for the items you have purchased with that system. User installed systems should be configured using the Setup programs that come with Gamry Instruments' Windows based application software.

This appendix is used when manual configuration is convenient or required. It includes:

- A description of the "GAMRY.INI file
- Instructions for changing the Auxiliary D/A ranges.
- Instructions for changing settings for the Auxiliary A/D input

About the "GAMRY.INI" File

The "GAMRY.INI" file contains system configuration information. This file is used to:

- Store Potentiostat names.
- Store auxiliary equipment configurations (multiplexers and temperature controllers).
- Authorize use of a specific potentiostat by specific software packages.
- Store calibration data for each potentiostat.
- Store scaling factors for system D/A and A/D converters.
- Store software configuration information.

The "GAMRY.INI" file is an ASCII file that is divided into sections identified by a section name in square brackets (e.g. [EIS300]). Each section contains settings for a specific aspect of the system.

You can modify the file using an ASCII editor or a word processor in a non-document mode (a mode with no formatting codes in the text). The Windows Notepad accessory is a convenient ASCII editor.

The copy of "GAMRY.INI" actually used by the software must be located in the Windows directory (normally C:\WINDOWS). The Setup programs provided with Gamry Instruments' software either install "GAMRY.INI" in the correct directory or ~~modifies~~ modify an existing file in this location.

A portion of a typical "GAMRY.INI" file is shown in Figure C-1. Only some of the information required for FAS2 configuration is shown. A complete "GAMRY.INI" file is longer than this example.

In Figure C-1, the 1st line is called a section identifier. The name of the section is enclosed in square brackets, e.g. [Framework]. The [Framework] section extends to the next section identifier [DeviceList]. The [Framework] section contains configuration information for the Gamry Framework program. This section is required in all "GAMRY.INI" files that configure a Gamry Framework System.

The section labeled [DeviceList] contains a list of all the potentiostats in the system. Each entry in this section corresponds to one potentiostat. The entry name is the name of the "GAMRY.INI" section that describes this potentiostat. In the sample file, the [DeviceList] contains only one entry (for Pstat0).

"GAMRY.INI" normally contains potentiostat calibration information (not shown). Each potentiostat's data is in its section. You do not normally have to edit the calibration data which is automatically created and updated by the calibration routine built into the software.

Appendix B -- Changing The Default FAS2 Settings -- About the "GAMRY.INI" File

The [Pstat#] section also contains the AUXDACRES field which you may need to change. See below for details.

Notice the section labeled [InterruptList]. Unlike previous revisions of the Gamry Framework, Revision 4.0 no longer assigns IRQ's using this section. A simple line "IRQAuto=" tells the software that the IRQ levels are assigned by the Windows Device Manager.

Figure C-1
Portion of a Typical "GAMRY.INI" File

```
[Framework]
Version=4.20
SystemDir=C:\Program Files\Gamry Instruments\Framework\
ScriptDir=C:\Program Files\Gamry Instruments\Framework\Scripts\
PACKAGE0=DC105

[DeviceList]
PStat0=

[PStat0]
CMSDriver=PCI4.DLL
LABVIEWDriver=PCI4LV.DLL
BaseAddress=
PstatClass=PCI4
FraCurveClass=FRACURVE4
BoardNo=1
SerialNo=12345
Label=My FAS2
AuthDC105=1234567890
AUXDACRES=2.5E-3,0
...

[InterruptList]
IRQAuto=

[ECM8_1]
TYPE=ECM 8
LABEL=My ECM8
PORT=2
MODE=COM2:9600,N,8,1
SerialNo=12345

[DC105]
NAME=DC Corrosion
```

```
EXPT1=Corrosion Behavior Diagram,Corrosion Behavior Diagram.exp  
EXPT2=Corrosion Potential,Corrosion Potential.exp  
...
```

Changing "GAMRY.INI" using Setup

The Framework Setup program that comes with Gamry Instruments' software can automatically make changes in the "GAMRY.INI" file. You can use this program to change [EPStat](#) identifier information in "GAMRY.INI".

Using Notepad to alter "GAMRY.INI"

It is often convenient to use an ASCII editor to make small changes in [the "GAMRY.INI" file](#). The Notepad accessory included with Windows is a useful ASCII editor. Please read the Microsoft documentation for full instructions about using [it Notepad](#).

Removing a Potentiostat from an Existing System

To remove a potentiostat from a system you need to do two things.

- 1) Physically remove the card set from the computer.
- 2) Remove the potentiostat's PstatX= field from the [DeviceList] section in the "GAMRY.INI" file (where X stands for the zero based board number of the potentiostat you are removing).

Interrupt Level Setting

Most peripheral devices in an AT compatible computer coordinate I/O (input/output) operations with the microprocessor by means of hardware interrupts. An interrupt is a request by a device that the computer suspend the program it's currently running, and perform an I/O operation. The FAS2 Potentiostat generates an interrupt at the end of each data point.

All PCI devices in a computer generally share one interrupt level.

Register Address

The FAS2 Potentiostat card set, like virtually all IBM compatible expansion cards, has hardware registers that the computer must be able to access. These registers are located at a specific address in the memory address space of the computer's microprocessor. Addresses are expressed in the hexadecimal numbering system where the digits are 1,2,3,4...8,9,A,B,C,D,E,F. We will always precede a hexadecimal number with the prefix 0x, e.g. 0x22F.

The FAS2 requires a 64 byte memory space for its hardware control registers.

Changing the Auxiliary Analog Output Scaling

A setting in the "GAMRY.INI" file allows you to change the scaling of the D/A converter used to generate the auxiliary analog output.

The default setting configures this D/A converter for a bipolar output of ± 5 volts with a bit resolution of 2.5 mV/bit. You can switch to a unipolar output of 0 to 10 volts, still with a bit resolution of 2.5 mV/bit.

The D/A scaling is controlled by a field in the [PStat#] section of the "GAMRY.INI" file. This field has the form:

```
AUXDACRES=2.5E-3,0
```

The final 0 indicates that the scaling is bipolar. If this digit was a 1, the scaling would be unipolar.

Appendix C -- I/O Connections for the FAS2

The FAS2 Femtostat has a number of connectors that allow it to communicate electronically with the world outside of the computer. This appendix describes these connectors and the signals available on their pins.

Grounds and the FAS2 Femtostat

The FAS2 has been specially designed for operation with cells in which one of the electrodes is connected to earth ground. Earthed electrodes often occur in field experiments, because metal pipelines and structures are generally earth grounded. In the lab, experiments involving either autoclaves or stress apparatus often have earth grounded electrodes. Conventional potentiostats do not work properly or safely in these experiments. In the typical glass or plastic test cell, none of the electrodes are earthed, so no grounding problems arise.

The FAS2 analog circuits are electrically isolated from the computer's chassis which is at earth ground. Another name for circuits that are isolated is "floating". The isolation is accomplished by means of optical isolators and transformers.

Extraordinary measures were taken in the design of the FAS2 to ~~try and~~ maximize the degree of isolation. However, you can still measure higher impedances (smaller currents) on cells that are not earth grounded than you can on earth grounded cells.

If you are working with earthed electrodes, ground connections for your potentiostat are critical. You must be careful that the floating ground connection on all FAS2 connectors does not get connected to earth ground.

We strongly recommend that you use an earth grounded Faraday shield whenever you are measuring small currents. See Chapter 5 for a discussion of Faraday shields.

The Cell Connections

Basic cell connections are described in some detail in Chapter 3. That information will not be repeated here.

In a few cases, you may find that you need cell connection cables that differ from those shipped with your FAS2. By far the easiest changes involve modifying a standard cable. We can sell you an extra cable for this purpose.

If you need to modify a cable or make a completely new one, the following information may be helpful.

- SMC connectors are available from several manufacturers.
- SMC adapters to other cable types including BNC cables are also generally available.
- We recommend that you use shielded coax cables for all the cell connections.
- Connect the shield of the coax at the SMC connector end of the cable. Leave the shield open on the cell end.
- Do not ground any shields!
- Use good quality cable and keep the termination clean. You want at least 1000 G Ω of isolation between the shield and the inner conductor.
- Longer cables can dramatically slow the FAS2, especially on sensitive current ranges. This may cause potentiostat stability problems.

Aux A/D Input

This input allows you to measure an externally generated voltage signal. The Aux A/D input is the top SMC connector on the FAS2 Controller Card's minipanel. See Figure C-1 for the identity of all the SMC connectors on this minipanel.

Uses of this input include the measurement of temperature, strain, or other non-electrochemical parameters. This input is fully differential, with about 80 dB of common mode rejection. Be careful though, the allowed common mode voltage range is only ± 11 volts with respect to the floating ground. Voltages outside this range should not damage the instrument but they cannot be measured.

The input impedance is 25 k Ω on each leg of the differential input. You may have to take this into account if the signal source connected to this input has a significant output impedance.

The scaling on this signal is ± 3 volts full scale, resulting in $\pm 30,000$ counts on the A/D converter.

Control Signal Input

The Control Signal Input allows you to inject a signal into the FAS2's potential or current control circuits. One use for this input is modulation of the applied voltage or current.

This input is the upper-middle SMC connector on the Controller Card minipanel. See Figure C-1 for the identity of all the SMC connectors on this minipanel.

Figure C-1
SMC Connectors on the FAS2 Controller Card Mini-panel

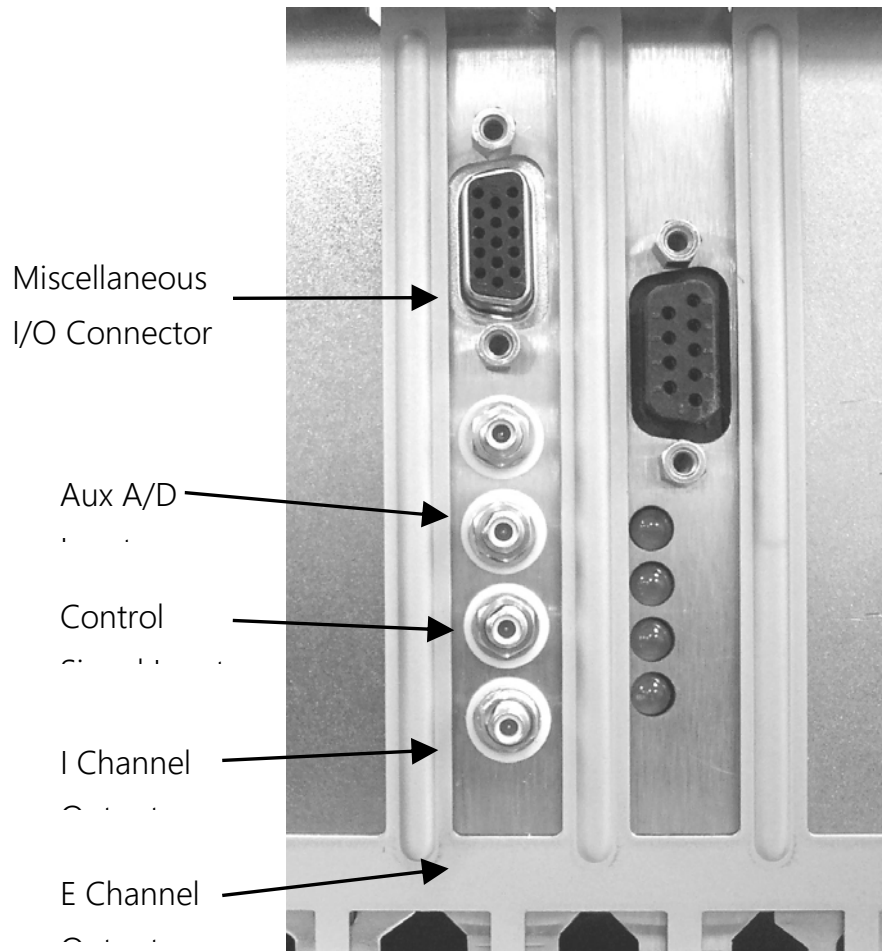

Note that the shell of this BNC connector is connected to the FAS2's floating ground. Connecting an earth ground referenced signal source to this input will cause problems if you are using the FAS2 with a cell that has an earth grounded electrode.

In controlled potential mode (and ZRA mode), the potential applied to the cell is the sum of the applied potential and the control input voltage. For example, if the programmed voltage is +2 volts, and +1 volt is applied to the control input, the cell voltage ($E_{\text{work}} - E_{\text{ref}}$) will be +3 volt. The input impedance of this input is 10 k Ω . Adding a control resistor, R_{ext} , in series with the input allows you to alter the scaling factors. The equation describing the relationship is:

$$V_{\text{cell}} = V_{\text{sig}} \times 10 \text{ k}\Omega / (R_{\text{ext}} + 10 \text{ k}\Omega)$$

V_{sig} is the signal applied to the resistor and V_{cell} is the resulting cell voltage. If 90 k Ω is added in series, a 1 volt signal will be attenuated to cause only a 100 mV cell voltage.

In controlled current mode, you will get full scale current for 3 volts applied to this connector. The current will vary with the current range. For example, on the 30 mA range, 1.5 volts will give you 15 mA of cell current. The sign is such that a positive input gives you a cathodic current.

I Channel Output

This output reflects the cell current signal as seen by the FAS2 A/D converter. The I Channel output is the upper-middle SMC connector on the FAS2 Controller Card's minipanel. See Figure C-1 for the identity of all the SMC connectors on this minipanel.

The signal on this connector has been through a long and complex analog signal processing chain. It may have been filtered, offset by a DC voltage, and gained. All of these functions are under computer control. The meaning of the signal on this connector is therefore highly dependent on the program controlling the FAS2 and cannot be described simply here. The one thing that can be said concerns polarity. If this signal becomes more positive as a result of changes in the cell potential, the cell current has become more anodic.

Note that the shell of this SMC connector is connected to the FAS2's floating ground. Connecting an earth ground referenced measurement device to this output can cause problems if you are using the FAS2 with a cell that has an earth grounded electrode.

V Channel Output

This output reflects the cell voltage signal as seen by the FAS2 A/D converter. The V Channel output is the bottom SMC connector on the FAS2 Controller Card's minipanel. See Figure C-1 for the identity of all the SMC connectors on this minipanel.

The signal on this connector has been through a long and complex analog signal processing chain. It may have been filtered, offset by a DC voltage, and gained. All of these functions are under computer control. The meaning of the signal on this connector is therefore highly dependent on the program controlling the FAS2 and cannot be described simply here. The one thing that can be said concerns polarity. If this signal becomes more positive as a result of changes in the cell potential, the cell voltage has become more anodic.

Note that the shell of this SMC connector is connected to the FAS2's floating ground. Connecting an earth ground referenced measurement device to this output can cause problems if you are using the FAS2 with a cell that has an earth grounded electrode.

Miscellaneous I/O Connector

This connector contains a number of chassis ground related signals. It is the miniature 15 pin female D shaped connector on the FAS2 Controller Card. Be careful, the ground on this connector is not the FAS2 floating ground. Connecting the two grounds may lead to problems if you are using the FAS2 in a floating mode.

The auxiliary analog output, derived from a D/A converter, is on this connector. The scaling is normally 2.5 mV per bit, for a ± 5 volt full scale range. These ranges can be altered via the AUXDACRES field in the "GAMRY.INI" file.

The pinout of this connector is shown in Table C-3.

Table C-3
Miscellaneous I/O Connector

Pin	Name	Use
1	Analog Output Low	The auxiliary output ground connection.
2	Analog Output High	The auxiliary output signal.
3	no connection	
4	Start of Point	A TTL pulse before the start of a data point
5	End Of Point	A 1 μ sec TTL pulse at the end of each data point
6	Ground	Digital ground
7	Digital Out 0	A CMOS digital output- 330 Ω output impedance
8	Digital Out 1	A CMOS digital output- 330 Ω output impedance
9	Digital Out 2	A CMOS digital output- 330 Ω output impedance
10	Digital Out 3	A CMOS digital output- 330 Ω output impedance
11	Digital In 0	A TTL digital input- 2.2 k Ω input impedance
12	Digital In 1	A TTL digital input- 2.2 k Ω input impedance
13	Digital In 2	A TTL digital input- 2.2 k Ω input impedance
14	Digital In 3	A TTL digital input- 2.2 k Ω input impedance
15	+5 Volts	Power- 100 mA maximum current

Appendix D – Auxiliary A/D Input Characteristics

Overview

The Controller Card used in the Gamry Instruments FAS2 Potentiostat has jumpers that configure the input circuitry used for the Aux A/D function.

Jumper Identification

The three jumpers that configure the Aux A/D input are in a cluster located at the right side of the Controller Card. The four coax cables that route analog I/O to the card enter the card just above these jumpers. See the figure to the right for jumper locations.

Figure E-1
Auxiliary A/D Input Configuration Jumpers
View of PCI4 Controller Card

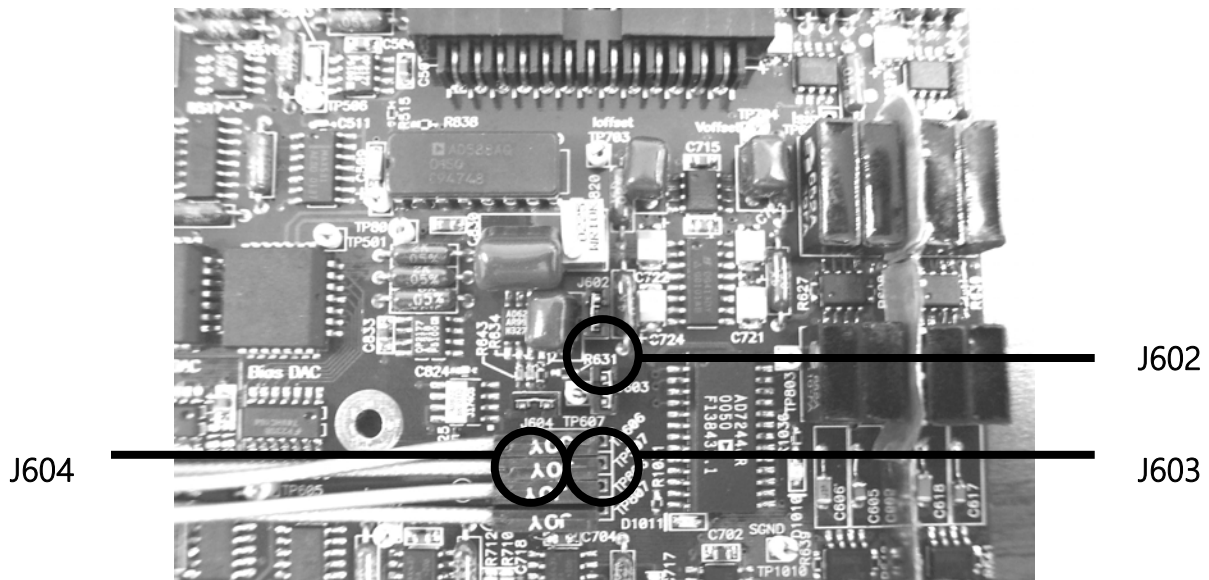

Input Impedance Selection

Two jumpers are associated with the input impedance – J603 and J604. With J603 and J604 installed, the Aux A/D inputs have a 100 k Ω input impedance. This is the default setting. With the jumpers installed, the potentiostat can be calibrated without a cable on the input SMC connector.

With both J603 and J604 removed, the Aux A/D input impedance is 10 G Ω (typically). This setting is suitable for use with a high impedance source such as a reference electrode. If you have removed these jumpers, do not calibrate the potentiostat unless you have a cable connecting both Aux A/D inputs to floating ground.

Filter Selection

J602 controls filtering of the Aux A/D input. With J602 removed, there is no filtering on this input. With J602 in place (the default setting), a single pole RC filter is used to limit noise into the A/D. The nominal cutoff frequency of this filter is 20 Hz.

Note that source impedances greater than 1 k Ω will appreciably lower this cutoff frequency. When the Aux A/D input is driven by a source with an output impedance of 1 M Ω , the frequency cutoff will be less than 0.25 Hz.

Aux A/D Specifications

These specifications apply to all FAS2 boards:

Range	± 3.276 volts	
Input Impedance	100 k Ω (approx)	J603 & J604 installed
	or 10 G Ω (typical)	J603 & J604 removed
Input Bias Current	< 10 nA	J603 & J604 removed
Filter Cutoff	20 Hz \pm 20%	J602 in place with

--

$Z_{\text{source}} < 1 \text{ k}\Omega$

Comprehensive Index

[Framework] Section in GAMRY.INI, 6-6

0x for Hexadecimal Numbers, 1-5

ancillary apparatus, 5-8

autoclave, 6-9

Aux A/D Input, 6-10

auxiliary electrode, 3-2

black banana plug, 3-2

calibration, 2-6

 data, 6-6

capacitive cells, 4-1

CE Compliance, 1-1

cell construction materials, 5-7

cell leads, 3-1, 5-6

computer requirements, 2-1

computers - noise, 5-6

Control Signal Input, 6-10

conventions

 notational, 1-5

 positional, 2-2

counter electrode, 3-1

earth ground, 3-2, 5-5, 5-8

EIS speed, 5-7

electrical noise, 5-5

electrons per second, 5-1

Faraday shield, 3-2, 5-5

FAS2, 1-1

 floating ground, 6-9, 6-11, 6-12

floating ground, 3-2

floating operation, 5-8

fluorescent lights, 5-6

Gamry Framework, 1-1

GAMRY.INI, 2-6, 6-6

ground, 5-6, 6-9

hexadecimal numbers, 1-5

high frequency shunt, 4-3

hints, 5-5

I Channel Output, 6-12

I/O address, 6-8

I/O connections, 6-9

input capacitance, 5-1

input current, 5-1

input impedance, 5-1

input leakage current, 5-4

installation

 Controller Card, 2-4

interrupt level

 changing, 6-8

Johnson noise, 5-2

lead capacitance, 5-6

lead placement, 5-6

Lugin capillary, 4-2, 5-7

materials, 5-7

measurement system model, 5-1

miscellaneous I/O connector, 6-13

motors, 5-6

Multiple Potentiostat Systems, 2-3

noise, 5-4

Notepad, 6-6, 6-7

oscillation, 4-1

PCI Compatibility, 2-1

Plug, 2-3

radio transmitters, 5-6

reference electrode, 3-1, 5-7

 impedance, 5-7

removing a card set, 6-8

ringing, 4-1

schematic, 1-2

small signals, 5-1

stability, 4-1

static discharges, 2-2

stress apparatus, 6-9

turn-key system, 2-1

V Channel Output, 6-12

voltage noise, 5-4

working electrode, 3-1