

A Potentiostat Buying Guide

All the information you should be considering when looking to purchase the potentiostat for your application



GAMRY
INSTRUMENTS

How to Buy a Potentiostat

CONTENTS

1. Useful questions.....	3
2. Basic information.....	5
3. Parameters and Applications.....	6
4. Instrument components	7
5. Accuracy contour plot	9
6. Specifications of a Potentiostat	10
7. Examples of instruments available	14





1. USEFUL QUESTIONS

Do I need a general-purpose potentiostat or a high-performance potentiostat?

The type of work you will be doing can drive the type of potentiostat you will need. For instance, most benchtop work studying the corrosion of materials, inhibitors, catalysis, and materials for batteries or supercapacitors doesn't require a high-performance potentiostat. Studying insulating coatings or highly corrosion resistant materials or needing high sampling rates for something like fast-scan CV can require a high-performance potentiostat.

Do you need a potentiostat for high-power devices?

Before purchasing a potentiostat, it's always a good idea to determine the requirements of your experiment(s) to ensure that the device will suit your needs. At the same time, ascertaining your specifications before investing in a potentiostat can steer you clear of spending extra on bells and whistles that you won't use. For instance, it doesn't make sense to buy a potentiostat with a maximum current of several amperes when measurements in the milliamperere region are performed. Investment costs for high-power instruments are typically higher because their complexity increases.



1. USEFUL QUESTIONS

Should it be portable or is a stationary system sufficient?

Portable potentiostats are small, easily transportable units that have a lower price point with easy-to-use software that covers all main electrochemical techniques. Portable potentiostats are perfect for those working in research areas such as laboratories, classrooms, and in the field. While stationary potentiostats take up a larger footprint and are not easily mobile they do typically offer more versatility. When trying to choose between using a stationary or a portable potentiostat you must look at where the unit will be used and what testing you need to perform. Once those questions are answered you will easily be able to decide between the two.

Can it be a single potentiostat or is a multi-channel system required?

Understanding the differences between a single and a multi-channel potentiostat can help you determine

which system you need. A single potentiostat is perfect for research level applications. They can control a single voltage and measure the resulting current. Multi-channel potentiostats are made up of multiple single channels operating as one unit; they can measure independently, in groups or congruently. Which system to use can easily be determined once you know what kind of testing and throughput you need.

How much support will you need?

Are you new to potentiostats and will need some training and resources to help you get started? Or do you have plenty of experience and can troubleshoot issues on your own when they arise? These are also important questions you need to ask yourself. Having reliable, helpful support can save you both time and money.

2. BASIC INFORMATION

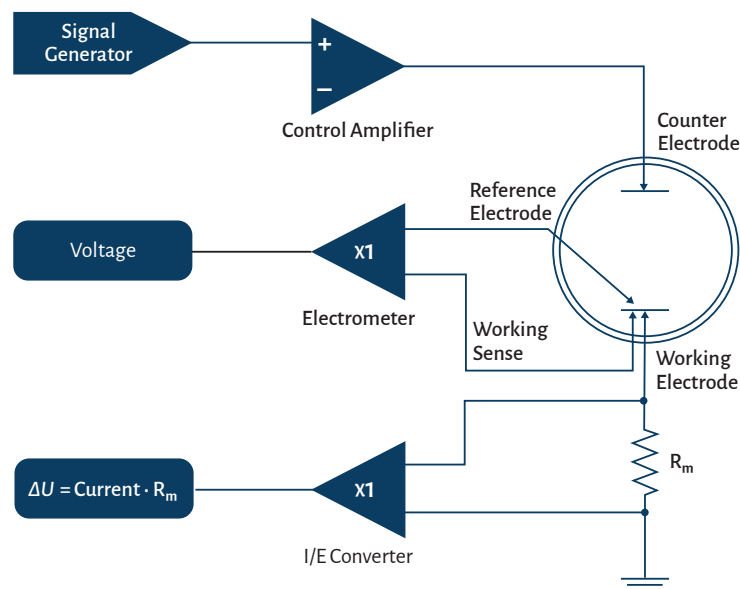

Figure 1: A Simplified schematic of a potentiostat.

In almost all applications, the potentiostat measures the current flow between the working and counter electrodes and the potential difference between the working and reference electrodes. The potentiostat is attached to an electrochemical cell using working, working sense (for measuring the potential of the working electrode), counter, and reference electrode leads. The working electrode is typically the electrode used for studying any electrochemical processes.

Below is a schematic that shows a block diagram of the internal workings of a potentiostat. In simplified terms, the Signal Generator creates the signal form requested from the user (e.g., constant value, ramp, sine wave) and sends it to the Control Amplifier. The Control Amplifier applies the signal to the cell and adjusts its amplitude so that it corresponds to the user's input value. The instrument can operate in two different modes even though we almost always call the instrument a potentiostat. The instrument can operate as a potentiostat (applied voltage) or as a galvanostat (applied current). Most instruments also

have the capability to operate as a Zero Resistance Ammeter which is a special mode of operation where the working and counter electrodes are “shorted” through the instrument and both voltage and current are monitored.

The potential difference between reference and working electrode is measured using an Electrometer. Additionally, the measured voltage signal is sent back to the control amplifier where it is compared to the desired input value. The control amplifier will continue to output current until the two inputs are identical.

The current flow through the cell is measured at the Current-to-voltage Converter (I/E Converter). This is done by measuring the voltage across a resistor (R_m) in the I/E Converter. The measured voltage drop U across the resistor is directly proportional to the current flow I through the cell (Eq. 1).

$$\Delta U = R_m \cdot I$$



3. PARAMETERS AND APPLICATIONS

A single instrument cannot meet all requirements – especially if you consider investment costs as an additional and equally important factor. Specification sheets tell you what an instrument is capable of and help also to narrow down the list of instruments suitable for your applications. Depending on what you want to do, some specifications are more relevant than others. But ask yourself: Do you understand the meaning of the parameters listed in a specification sheet and can you order them according to priority of importance for your needs?

3.1 Batteries/Fuel Cells/Supercaps

Are you testing materials, cells, or stacks? Materials and small cell testing don't require the large currents that bigger cells and stacks require. Do you have to stress your cells at high charge/discharge rates? Do you need impedance capabilities?

3.2 Corrosion/Coatings

Electrochemical corrosion measurements and measurements on coated samples typically require the ability to measure small currents. Additionally, you need to consider if you are going to be testing grounded cells or electrodes. For instance, are you testing samples in the field, or are you testing samples in an autoclave or other grounded vessel? You'll need an instrument that has high electrical isolation from Earth ground. Finally, you'll also need to consider sampling rates – most electrochemical corrosion experiments don't have high samplings rates.

3.3 Physical Electrochemistry

Experiments that fall within this category typically include sweeps, steps, and pulsing techniques. Currents can range from sub-uA to mA depending on the type of electrode being used (macro versus micro versus ultramicro). Most of these experiments are three-electrode experiments in an isolated cell so a floating potentiostat is not a necessity. However, if you are coupling the potentiostat to another instrument such as an AFM or SECM then you do need true floating capability. Or if you are doing rotating-ring disc experiments with two potentiostats then you will need electrical isolation.

3.4 Sensors

Electrochemical sensors are very similar in instrumentation needs to Physical Electrochemistry. What is different though is at times is the need for rapid, biphasic pulsing. Stressing electrodes is often done using unique waveforms so having the ability to customize your waveforms could be an important consideration.



4. INSTRUMENT COMPONENTS

Channel-to-channel Isolation

Electrochemical measurements necessarily require multiple signal channels from the various electrodes in your cell or test equipment. Each of these signal channels ideally should not affect another channel. That is - the channels are isolated from one another.

Ultimate Resolution

For the best possible analog-to-digital resolution, instruments should start with at least a 16-bit A/D converter, controllable noise filters to remove any noise in the channels, and run the signal through controllable amplifiers with a gain of up to $\times 100$, which is nearly 2^7 , or almost an extra 7 bits of resolution. This gain is added to the A/D converter getting an ultimate resolution of almost 23 bits that is noise-free.

Frequency Resolution

In electronics, the frequency resolution Δf can be defined as the inverse of the sampling time.

With a 32-bit direct-digital synthesis (DDS) clock an instrument should see a frequency resolution of $1/2^{32}$. However, frequency resolution doesn't ensure the highest accuracy for impedance. The Accuracy Contour Plot is the most useful measure for impedance accuracy.

Trim Potentiometers

An instrument should have no trim potentiometers for fine-tuning its performance. Rather all the adjustments should be performed in software so that returns to the factory for trim-calibration are rarely needed. Trim components are susceptible to mechanical shock and variations in temperature.

Only Surface-mounted Components

A potentiostat is best constructed with only surface-mounted electronic components. Surface-mounted components mean a smaller volume, and less fluctuation in temperature, which gives you less drift and more accuracy when you take data.



4. INSTRUMENT COMPONENTS

No Cables, Harnesses, or Interconnects

The potentiostat you select should not contain harnesses or interconnects inside its chassis. This will provide superior mechanical reliability (no connections to become loose), less stray EMF interference, and fewer chances for internal corrosion at contacts. Minimizing such metal-to-metal contacts will provide the instrument with lower drift and overall better stability.

Low-noise Power Supply

Using a low-noise primary switching power supply in the potentiostat eliminates EMF interference with your desired signal. It is also a high-efficiency supply, which means there is less heat generated, and a greener usage-profile.

Specially Designed Chassis

Look for a potentiostat that uses a chassis created to optimize removal of heat to maintain a constant temperature. In addition, the chassis should include a special guided airflow designed to cool the electronics consistently. This chassis will contribute to low drift, high accuracy, and stable measurement conditions.

Variable-speed Fan

A potentiostat should include a computer-controlled variable-speed fan inside the chassis to cool internal electronics. The fan would be designed to keep a constant temperature. Fans, which are necessarily built with electric motors, create a small amount of electrical noise. Removing the fan from the proximity of sensitive components will avoid induced noise in your signal. In addition, a variable-speed fan is quieter, which is important in a busy laboratory environment.



5. ACCURACY CONTOUR PLOT

The impedance measurement is a collective representation of all components of a system – the cell, the instrument, and the connecting cables. However, instruments are not always capable of measuring the cell correctly. They are subject to restrictions which limit the range and the accuracy.

This figure shows a general scheme of an Accuracy Contour Plot. The graph is a log-log plot, fashioned as a Bode-type plot. The magnitude Z_{mod} of the impedance is plotted versus frequency f .

The hatched area indicates the region in which EIS measurements can be done in a specific accuracy. Beyond this region, measurements are untrustworthy as accuracy is highly uncertain. A more specific form of an Accuracy Contour Plot is shown below for the Reference 620. Note that there are two regions outlined here – $<1\%$ and $<10\%$. These regions indicated the error in accuracy for that region. Accuracy contour plots should be generated using typical data acquisition conditions and include a cell cable.

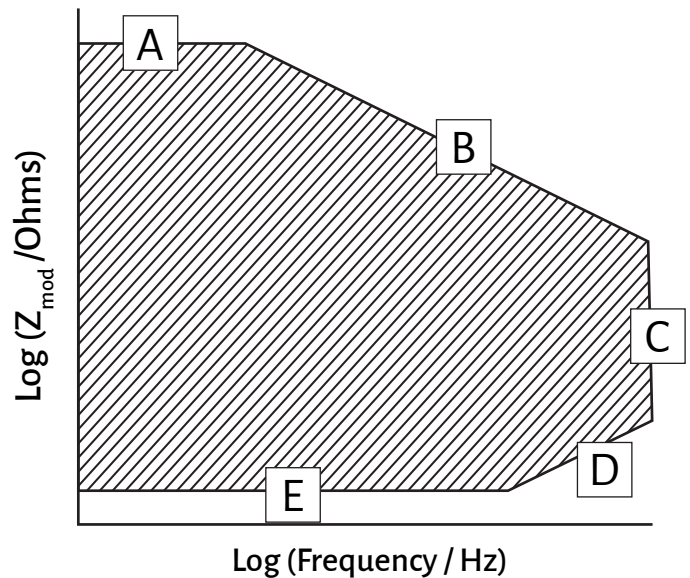

Figure 2: Generic form of an Accuracy Contour Plot

6. SPECIFICATIONS OF A POTENTIOSTAT

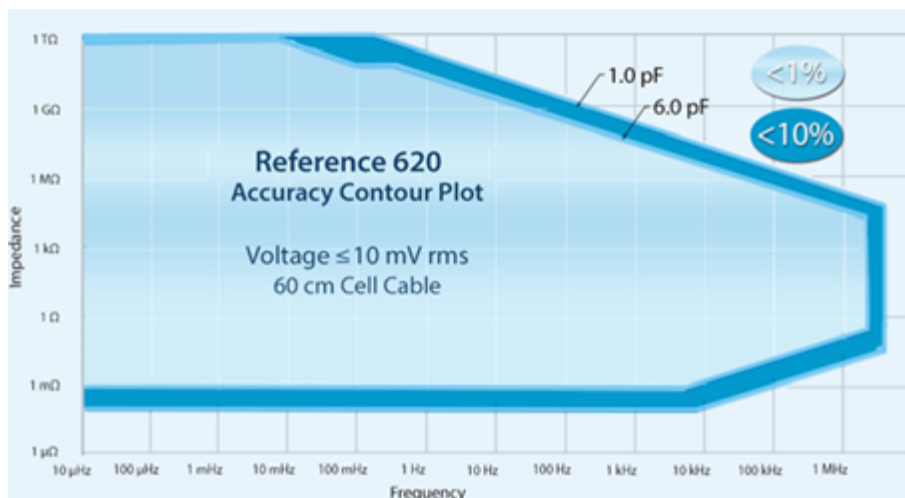

Figure 3: Accuracy Contour Plot for Gamry's Reference 620

Specifications of a potentiostat should fit the requirements of the experiments you want to perform. Below we discuss various terms which give valuable information about the capabilities of a potentiostat

System

Parameters in this section give a basic overview about a potentiostat. We list basic specifications to help narrow down your list of suitable instruments.

Cell connections

Most potentiostats support 2-, 3-, and 4-electrode setups using a Working, Working Sense, Counter, and Reference lead. These three setups cover most electrochemical applications.

For more information on electrode setups, see Gamry's application note [Two-, Three-, and Four-Electrode Experiments](#)

Some potentiostats are equipped with auxiliary electrometer channels (AUX channels). They can be used for voltage sensing of multiple reference electrodes or monitoring single cells in stack configurations, e.g., multiple batteries in a serial connection.

Maximum current

Maximum current specifies the upper current limit of a potentiostat and relates to the applied as well as measured current.

When searching for a potentiostat, we advise you to evaluate first how much current you need for your experiments.



6. SPECIFICATIONS OF A POTENTIOSTAT

Current ranges (including internal gain)

Current ranges (also referred to as I/E ranges) allow measurement of a wide range of currents over several decades without losing precision. Specification sheets typically list the number of current ranges as well as the lowest and highest available current range. Additionally, some specification sheets include the gained ranges. Be sure you know how much gain is being applied on those additional ranges. Gains can be useful but remember that gaining the signal also gains the noise and if you're not properly dealing with the noise there's no additional benefit to gain.

Maximum applied potential

Maximum applied potential describes the maximum voltage a potentiostat can apply to a cell or measure between Working Sense and Reference Electrodes. If this value is exceeded, a voltage overload (V OVLD) signal appears in Gamry's Framework software.

Do not confuse the maximum applied voltage with the compliance voltage of a potentiostat. The compliance voltage affects the maximum voltage that the Control Amplifier can apply between Counter and Working Electrode (see below).

Rise time

The rise time represents the time that it takes for a signal to rise or fall. Usually, it is specified as the time between 10 % and 90 % of the signal's amplitude (see Figure 3). The shorter the rise time, the faster a system can react to a signal change. This is especially important when measurements are performed that require fast signal changes such as pulse voltammetry or impedance spectroscopy.

Minimum timebase

The minimum timebase is the fastest possible sampling rate of a potentiostat, usually in the microsecond range.

Keep this parameter in mind for experiments that involve measuring fast signal changes and where high time-resolution is important, such as reaction kinetics or signal-decay experiments.



6. SPECIFICATIONS OF A POTENTIOSTAT

Noise and ripple

Noise and ripple are two terms that describe the overall noise of the Control Amplifier's output signal. The magnitude of the total noise is usually listed as root-mean-square (rms), peak-value (pk), or peak-to-peak value (p-p).

Controller Amplifier

The Control Amplifier (CA) controls and adjusts the signal that is applied to a cell. Various parameters that are limited by the CA are mentioned above. The following section contains additional parameters related to the control amplifier.

Compliance voltage

The compliance voltage is the maximum voltage that can be applied by the CA between Counter and Working Electrode. Note the difference to the maximum applied voltage. The compliance voltage is higher than the maximum applied voltage and is used to adjust the user-defined potential on your cell. Compliance voltage is one specification to consider when working with highly resistive cells.

For more information on compliance voltage, see Gamry's application note: [Compliance Voltage: How Much is Enough?](#)

Speed settings

The control amplifier can be driven by different speeds (CA speed). They also relate to the unity-gain bandwidth of the CA as well as the slew rate (see later).

Faster speed settings allow the control of fast signal changes. However, this also affects the potentiostat's stability, which becomes even more apparent when capacitive cells or reference electrodes with higher impedances are connected.

For more information on improving the stability of your potentiostat, see Gamry's application note: [Tips and Techniques for Improving Potentiostat Stability](#)

Unity-gain bandwidth

One specification strongly related to the CA speed is the unity-gain bandwidth. Increasing the CA speed also increases the unity-gain bandwidth. It describes the frequency at which the gain of the CA is one (1). Signals up to this frequency can be amplified. Signals are attenuated when exceeding the unity-gain bandwidth, which can lead to distortion and noise.



6. SPECIFICATIONS OF A POTENTIOSTAT

Slew rate

The slew rate is also related to the potentiostat's speed setting. While the bandwidth represents the frequency domain, the slew rate shows the behavior in the time domain. As shown in Figure 3, it represents the slope of an applied signal. Its value can be changed by changing the CA speed settings. High speed settings allow processing fast signal changes with high slew rates. Decreasing the CA speed increases the potentiostat stability but decreases the slew rate.

Electrometer

The Electrometer measures the voltage difference between the reference and working electrodes. In addition, it sends back the signal to the CA which then counteracts any deviations between requested and measured potential. This section includes additional limitations of the Electrometer.

Input current

The input current describes the typical current flow through the Electrometer. This parameter should be very small to minimize current flow through the Reference Electrode. This way, unwanted Faradaic

reactions within the Reference Electrode can be avoided and its potential can be held constant.

Input Impedance

To keep the input current small, the Electrometer requires a high input impedance. It is also often described by an input resistance as well as input capacitance. A small input capacitance helps avoiding system instabilities when using high-impedance reference electrodes.

For more information on open lead experiments and EIS on coatings, see Gamry's application note: [EIS of Organic Coatings and Paints](#).

Electrometer bandwidth

The electrometer bandwidth describes the ability of how fast the Electrometer can measure signal changes. This value is usually much higher than the practical frequency range of the potentiostat.

Common-mode rejection ratio (CMRR)

The common-mode rejection ratio (CMRR) shows how good a differential amplifier (i.e., the Electrometer) can suppress unwanted signals caused by non-idealities of components and design limitations.

7. EXAMPLES OF INSTRUMENTS AVAILABLE

Gamry users cover a vast range of expertise and over half of our new users are new to electrochemistry. Gamry's products are especially well-suited for newcomers because they are easy to use, very reliable and come with a two-year Potentiostat guarantee.

Gamry's two families of potentiostats are the high-performance Reference line and the more value-oriented Interface line.

Reference Line of Instruments:



Reference 620

- Designed for fast, low-current measurements
- Fast CV
- High speed pulsing and sampling
- 11 V, 600 mA
- EIS to 5 MHz



Reference 3000

- Perfect for high and low current applications
- 32 V / 1.5 A and 15 V / 3 A
- EIS to 1 MHz
- Boostable to 30A



Reference 3000 AE

- Perfect for high and low current applications
- Boostable to 20A
- Additional voltage measurements for stacks and ancillary devices
- 32 V / 1.5 A and 15 V / 3 A
- EIS to 1 MHz

7. EXAMPLES OF INSTRUMENTS AVAILABLE

Interface Line of Instruments:



Interface 1010E

- General purpose
- Great for most applications except insulating coatings
- 12 V, 1 A
- EIS to 2 MHz



Interface 1010B

- The perfect introductory instrument for physical and analytical electrochemistry applications
- 12 V, 1 A



Interface 5000E

- High current testing of single cell energy devices
- Second voltage measurement for simultaneous anode and cathode measurements
- Temperature monitoring
- 6 V, 5 A
- EIS included



Interface 5000P

- Great introductory 5A instrument designed for testing of batteries, supercapacitors and fuel cells.
- 6 V, 5 A
- Dual voltage measurements
- Temperature monitoring
- EIS included (20 kHz (gstat mode only))



Multichannel



LP1010



Reference 3000 with Booster



gamry.com • +215-682-9330