



Interface 1000™

Potentiostat/Galvanostat/ZRA

Operator's Manual



Copyright © 2014–2015 Gamry Instruments, Inc.
Revision 6.22
September 4, 2015
988-00026

If You Have Problems

Please visit our service and support page at www.gamry.com/service-support/. This page contains information on installation, software updates, and training. It also contains links to the latest available documentation. If you are unable to locate the information you need from our website, you can contact us via email using the link provided on our website. Alternatively, you can contact us one of the following ways:

Internet	www.gamry.com/service-support/
Telephone	(215) 682-9330 9:00 AM - 5:00 PM US Eastern Standard Time (877) 367-4267 Toll Free US & Canada Only

Please have your instrument model and serial numbers available, as well as any applicable software and firmware revisions.

If you have problems in installation or use of a system containing an Interface 1000, it would be helpful if you called from a phone next to your computer, where you can type and read the screen while talking to us.

We will be happy to provide a reasonable level of free support for registered users of the Interface 1000 Potentiostat/Galvanostat/ZRA. Reasonable support includes telephone assistance covering the normal installation, use and simple customization of a computerized system containing an Interface 1000 connected to a Windows™ compatible computer.

A service contract that extends both the hardware warranty and software update period is available at an additional charge. Software updates do not include software enhancements offered to our customers at additional cost.

Enhancements to the Interface 1000 and Gamry's standard applications software that require significant engineering time on our part can be performed on a contract basis. Contact us with your requirements.

Limited Warranty

Gamry Instruments, Inc. warrants to the original user of this product that it shall be free of defects resulting from faulty manufacture of the product or its components for a period of two years from the original shipment date of your purchase.

Gamry Instruments, Inc. makes no warranties regarding either the satisfactory performance of the Interface 1000 Potentiostat/Galvanostat/ZRA including the software provided with this product or the fitness of the product for any particular purpose. The remedy for breach of this Limited Warranty shall be limited solely to repair or replacement, as determined by Gamry Instruments, Inc., and shall not include other damages.

Gamry Instruments, Inc. reserves the right to make revisions to the system at any time without incurring any obligation to install same on systems previously purchased. All system specifications are subject to change without notice.

There are no warranties which extend beyond the description herein. This warranty is in lieu of, and excludes any and all other warranties or representations, expressed, implied or statutory, including merchantability and fitness, as well as any and all other obligations or liabilities of Gamry Instruments, Inc; including but not limited to, special or consequential damages.

This Limited Warranty gives you specific legal rights and you may have others, which vary from state to state. Some states do not allow for the exclusion of incidental or consequential damages.

No person, firm or corporation is authorized to assume for Gamry Instruments, Inc., any additional obligation or liability not expressly provided herein except in writing duly executed by an officer of Gamry Instruments, Inc.

Disclaimers

Gamry Instruments, Inc. cannot guarantee that the Interface 1000 Potentiostat/Galvanostat/ZRA will work with all computer systems, operating systems, and third-party software applications hardware/software.

The information in this manual has been carefully checked and is believed to be accurate as of the time of printing. However, Gamry Instruments, Inc. assumes no responsibility for errors that might appear.

Copyrights

Interface 1000™ Potentiostat/Galvanostat/ZRA Operator's Manual -
Copyright © 2014, 2015 Gamry Instruments, Inc., all rights reserved.

Gamry Framework – copyright © 1989-2015, Gamry Instruments, Inc., all rights reserved.

Interface 1000™, Reference 3000™, Reference 600™, ECM8™, Gamry Framework™, DC105™, EIS300™, and Gamry™ are trademarks of Gamry Instruments, Inc.

No part of this document may be copied or reproduced in any form without the prior written consent of Gamry Instruments, Inc.

Table of Contents

If You Have Problems	ii
Limited Warranty.....	iii
Disclaimers.....	iv
Copyrights	iv
Chapter 1 -- Safety Considerations	1-1
Inspection.....	1-1
Product Safety	1-1
AC Mains Connection to the Power Brick.....	1-1
Grounding in the Interface 1000	1-2
Operation with Earth Grounded Cells and Auxiliary Apparatus.....	1-2
Temperature and Ventilation.....	1-3
Defects and Abnormal Stresses.....	1-4
Environmental Limits.....	1-4
Cleaning.....	1-4
Service	1-5
RF Warning	1-5
Electrical Transient Sensitivity	1-5
CE Compliance.....	1-6
RoHS Compliance	1-6
Chapter 2 -- Introduction.....	2-1
About this Manual	2-1
About the Interface 1000	2-1
Software and Applications.....	2-2
MultEChem Systems	2-2
Front Panel Personalization	2-3
Notational Conventions.....	2-3
Chapter 3 -- Installation	3-1
Initial Visual Inspection	3-1
Physical Location	3-2
Computer Requirements.....	3-2
Quick Start Guide for System Installation.....	3-2
Software Installation.....	3-2
Reboot your Computer after Software Installation.....	3-3
Power Cord and Power Connection	3-3
Power Up Test.....	3-4
USB Cabling	3-4
Multiple Potentiostat Systems.....	3-5
Cell Cable Installation	3-5
Front Panel USB LED	3-5
1 st Time Device Installation in Windows XP	3-5
Running the Framework.....	3-7
Framework Device Status Bar.....	3-8
Gamry Instrument Manager	3-9
Authorization Codes and Label	3-10
Firmware Update.....	3-12
Calibration.....	3-14
Separate AC Calibration for Each Interface 1000 Cable Type	3-14
DC and AC Calibration	3-14
The Interface 1000 Personalization Label	3-16

Introduction to the Interface 1000 Personalization Label.....	3-16
Label Sheet Provided With Each Interface 1000.	3-16
Label Files on the Gamry Website	3-16
Procedure to Change a Label	3-16
Chapter 4 -- Cell Connections	4-1
Normal Cell Connections	4-1
ZRA Mode Cell Connections	4-2
Membrane Cell Connections	4-3
Chapter 5 -- Panel Indicators and Connectors.....	5-1
Front Panel	5-1
Power Switch.....	5-1
Cell Connector.....	5-1
Monitor Connector	5-1
The Power LED.....	5-1
The USB LED.....	5-2
Cell LED	5-2
Overload LED.....	5-3
Personalization Label Area	5-3
Rear Panel	5-4
Power In Jack.....	5-4
Chassis Ground.....	5-4
USB Port.....	5-4
User I/O Connector.....	5-5
Sync Port	5-5
Chapter 6 -- Instrument Circuitry.....	6-1
Interface 1000 Schematic/Block Diagrams	6-1
Chapter 7 -- Stability in Potentiostat Mode	7-1
Capacitive Cells and Stability.....	7-1
Improving Potentiostat Stability	7-2
Chapter 8 -- Measurement of Small Signals.....	8-1
Overview.....	8-1
Measurement System Model and Physical Limitations.....	8-1
Johnson Noise in Z_{cell}	8-2
Finite Input Capacitance	8-3
Leakage Currents and Input Impedance.....	8-3
Voltage Noise and DC Measurements	8-4
Shunt Resistance and Capacitance.....	8-4
Hints for System and Cell Design.....	8-5
Faraday Shield	8-5
Avoid External Noise Sources	8-5
Cell Cable Length and Construction.....	8-5
Lead Placement	8-6
Cell Construction	8-6
Reference Electrode	8-6
Instrument Settings.....	8-6
EIS Speed	8-7
Ancillary Apparatus	8-7
Floating Operation	8-7
Appendix A -- Interface 1000 Specifications	8-1
Appendix B -- Interface 1000 Cell Connector	9-1
Appendix C -- I/O Connectors.....	9-1
User I/O Connector.....	9-1

Sync Port.....	9-1
Monitor Connector	9-2
I Monitor Signal	9-2
E Monitor Signal	9-3
External Signal In	9-3
Appendix D – Power LED Blink Codes	9-1
Normal Start-up.....	9-1
Failure in an electronics module.....	9-1
Severe problem	9-1
Error Messages and Limitations.....	9-1
Error Message This instrument is not authorized for Freq=	9-1
Error Message This instrument is not authorized for IERange=	9-1
Error Message This instrument is not authorized for ScanRate=	9-1
Error Message "This instrument is not authorized for SampleTime=	9-2
Appendix E – CE Certificate	9-1
Declaration of Conformity.....	9-1
Low Voltage Certificate of Conformance.....	9-2
RFI Certificate of Conformance	9-3
Appendix F -- Heat in Interface 1000 MultEchem Systems.....	9-1
Introduction to Device Power Dissipation.....	9-1
Potentiostat/Galvanostat Power Model	9-2
Discharging a Battery	9-2
Single Interface 1000	9-3
Vertical Stacks.....	9-3
Interface Power Hub Systems.....	9-3
Comprehensive Index	9-1

Chapter 1 -- Safety Considerations

Your Interface 1000 Potentiostat/Galvanostat/ZRA has been supplied in a safe condition. This chapter of the Interface 1000 Operator's Manual contains some information and warnings that you must follow to insure continued safe operation of the Interface 1000.

Inspection

When you receive your Interface 1000 Potentiostat/Galvanostat/ZRA you should inspect it for evidence of shipping damage. If any damage is noted, please notify Gamry Instruments Inc. and the shipping carrier immediately. Save the shipping container for possible inspection by the carrier.

WARNING

An Interface 1000 that has been damaged in shipment can be a safety hazard. Do not operate damaged apparatus until a qualified service technician has verified its safety. Tag a damaged Interface 1000 to indicate that it could be a safety hazard.

Product Safety

The Interface 1000 has been designed, tested and certified to meet the requirements of EN 61010, *Safety requirements for electrical equipment for measurement, control, and laboratory use*. As defined in this standard, it is a Category II apparatus, with any "hazardous live voltages" protected by "reinforced insulation".

Most of the Interface 1000 circuitry is a voltages low enough to be considered safe. The Interface 1000 contains a limited amount of internal circuitry that is at "hazardous live" voltages as defined in EN 61010 (the standard mentioned above). "Reinforced insulation" (again defined in EN 61010) is used to reduce the risk of electrical shock due to this hazardous live voltage.

The majority of the Interface 1000's circuitry does not contain voltages higher than 24 Volts DC. As a generalization, input and output voltages in the Interface 1000 are limited to 24 volts. This voltage level is considered safe.

The "AC Adapter" supplied with the Interface 1000 is certified under EN 60950. The AC Adapter converts the AC mains voltage to 48 volts DC, which is used to power the Interface 1000.

You should always use the AC adapter (power brick) supplied with your Interface 1000 to supply DC power to the instrument.

Warning

Use only Gamry Approved DC power sources with your Interface 1000. Other power sources may alter the performance and/or safety characteristics of the Interface 1000.

AC Mains Connection to the Power Brick

The Interface 1000 does not connect directly to an AC Mains supply. Instead, the mains are connected to desktop AC adapter (power brick), which outputs 48 volts DC, which in turn powers the Interface 1000.

NOTE

The Interface 1000's AC Adapter is rated for operation from 100 to 240 volts AC, 47 to 63 Hz. It should therefore be useful throughout the world.

The Interface 1000 is normally provided with an AC line cord suitable for your location. This AC line cord connects the AC mains to the AC power adapter. If your Interface 1000 has been provided without an AC line cord, or a cord that is not compatible with your local AC mains socket, obtain a line cord certified for use in your country. Contact your local Gamry Representative or Email to techsupport@gamry.com if you are uncertain what AC line cord to use.

Grounding in the Interface 1000

The circuitry and the metal case of the Interface 1000 are not connected to an earth ground. If they were connected to earth ground, it would compromise the Interface 1000's ability to make measurements in electrochemical cells that contain earth grounded metal. A few examples of such cells include autoclaves, metallographic stress apparatus, and detectors for capillary electrophoresis.

Most electrochemical cells are isolated from earth ground, so isolation of the Interface 1000 from earth is not required. In these cases, connection of the Interface 1000 chassis to an earth ground may lower the noise seen in an electrochemical test. A Chassis Ground banana jack on the rear panel of the Interface 1000 makes for easy implementation of this connection. Simply run a wire from this binding post to a suitable source of earth ground. A black 1.2-meter wire is provided with the Interface 1000 to facilitate this connection.

NOTE

Sources of earth ground include:

- Most metal water pipes,
- the chassis of most electronic apparatus (which are generally earth grounded), and
- the protective ground terminal of an AC Mains power plug.

We recommend that you discuss grounding with an electrical or electronics professional prior to making this earth ground connection.

Note this connection of the Interface 1000 to an earth ground is not a "Protective Earth Ground" as defined in EN 61010. The Interface 1000 is safe in the absence of this connection.

This binding post is not intended for any use other than connecting the Interface 1000 to an earth ground to improve shielding against noise. Connecting this binding post to a hazardous voltage can create a significant safety hazard.

WARNING

Do not connect the chassis ground binding post to any voltage other than earth ground. An improper connection can create a safety hazard, which could result in personal injury or death.

The Interface 1000 contains surge suppressors that limit the voltage difference between the Interface 1000's chassis ground and earth ground to about 28 volts. These surge suppressors are not part of the safety mechanisms in the Interface 1000. Instead they are present to limit the possibility of improper instrument operation or instrument damage due to electrostatic discharge (static electricity) and other surge events such as lightning.

Operation with Earth Grounded Cells and Auxiliary Apparatus

As described above, the Interface 1000 circuitry is isolated from earth ground, allowing it to make measurements on cells that include an earth ground. This ground isolation is often called floating

operation. Cells with earth ground include many autoclaves, pipelines and storage tanks, and many fuel cell systems.

Connection of the Interface 1000 to auxiliary apparatus will often earth ground the Interface 1000 destroying its ability to float and make measurements on earth grounded cells. Connection of the Monitor Connector to an oscilloscope is an example where the instrument is earthed.

The User I/O connector can be connected to earth grounded apparatus without earth grounding the Interface 1000, if the cabling is done carefully. The Metal Shell on the Interface 1000 User I/O Connector is connected to the instrument's chassis which is a Floating ground. In a system that needs isolation from earth ground, the shield of a User I/O cable must not connect the D-connector's metal shell to earth ground. All User I/O signals should be referenced to pin 6 of the D-connector, which is an earth ground on the Interface 1000.

Caution

Floating operation of Interface 1000 can be compromised by improper cabling to the User I/O Connector. We do not recommend use of standard 15-pin shielded cables with this connector. Custom cables with the shield connected to pin 6 of the D-connector are preferred.

Temperature and Ventilation

Your Interface 1000 Potentiostat/Galvanostat/ZRA was designed for indoor use at ambient temperatures between 0°C and 45°C.

The Interface 1000 uses forced air-cooling to keep the Interface 1000 components within their operating temperature range. Most of the air needed to cool the Interface 1000 enters the chassis through holes in its bottom plate. Some air also enters the chassis from small slots on the right side of the chassis (as viewed from the front of the instrument).

The fan within the Interface 1000 has two operating speeds with different audible noise levels. The Interface 1000 normally operates with the lower speed, quieter fan setting. The fan switches to a higher speed when the Interface 1000's internal heat-sink gets hotter than 50 °C.

The cooling air flows through a heat sink mounted inside the chassis. The air exits through a large array of slots on the left side of the instrument.

Caution

Do not block the airflow into or out of the Interface 1000 chassis. The circuitry is thermally protected so over temperature will cause the instrument to enter a shut down state. If shut down occurs during data acquisition experimental data could be lost. Running the Interface 1000 without adequate cooling could also shorten the time to failure of some of the circuitry.

Be careful when operating the Interface 1000 in an enclosed space (such as an enclosed relay rack or NEMA enclosure). The temperature within the enclosure must not exceed 45°C. You may need to provide ventilation holes or even forced air-cooling for the enclosed space if excessive temperature rise occurs.

Defects and Abnormal Stresses

You should treat your Interface 1000 as potentially hazardous if any of the following is true of the unit:

- it shows visible damage,
- it does not operate properly,
- it has been stored for a long period of time under unfavorable conditions,
- it has been dropped or subjected to severe transport stress,
- it has been subjected to environmental stress (corrosive atmosphere, fire, etc.).

Do not use your Interface 1000 or any other apparatus if you think it could be hazardous. Have it checked by qualified service personnel.

Environmental Limits

Note that there are environmental limit conditions on the storage, shipping and operation of this equipment. The Interface 1000 has not been designed for outdoor use.

Storage

Ambient Temperature	-40 °C to 75 °C
Relative Humidity	Maximum 90% non-condensing

Shipping

Same as storage plus Acceleration	Maximum 30 G
--------------------------------------	--------------

Operation

Ambient Temperature	0 °C to 45 °C
Relative Humidity	Maximum 90% non-condensing

Warning

The Interface 1000 is not designed for operation in conditions where liquid water may enter the chassis, or water vapor may condense within the chassis. Operation of an Interface 1000 that has water within the chassis can create a safety hazard, which could result in personal injury or death.

Cleaning

Disconnect the Interface 1000 from all power sources prior to cleaning.

Use a cloth lightly dampened with either clean water or water containing a mild detergent to clean the outside of the Interface 1000 enclosure. Alternatively, you can use isopropyl alcohol. Do not use a wet rag or allow fluid to enter the Interface 1000 enclosure. Do not immerse the Interface 1000 in any type of cleaning fluid (including water). Do not use any abrasive cleaners.

Service

Your Interface 1000 Potentiostat/Galvanostat/ZRA has no user serviceable parts inside. You should refer all service to a qualified service technician.

Warning

The Interface 1000 must not be operated with any cover or panel on the chassis open. Dangerous voltages may be present at several points within the Interface 1000 chassis, including PC board traces. Always remove the power connection before opening the Interface 1000 case.

RF Warning

The Interface 1000 has been tested for both radiated and conducted RF interference and for immunity to RF fields and has been found to be in compliance with FCC Part 18 and EN 61326:1998—*Electrical equipment for measurement, control, and laboratory use— EMC Requirements*.

However, your Interface 1000 Potentiostat/Galvanostat/ZRA does still generate some radio frequency energy. The radiated levels are low enough that the Interface 1000 should not create an interference problem in most industrial laboratory environments.

Your Interface 1000 Potentiostat/Galvanostat/ZRA can also respond to environmental radio frequency energy. We recommend you avoid using cell phone and other radio frequency equipment in the same room as an Interface 1000. The Interface 1000 circuitry has been tested for operation in high intensity RF fields and has demonstrated little response to those fields. However, there is no guarantee that the electrochemical cell and its connections will not respond to RF fields. This response will most often appear as DC shifts in a cell's response due to rectification of the RF signal.

A Faraday cage surrounding your cell can be used to minimize the effect of environmental RF fields. If your cell is isolated from earth ground, Gamry recommends connecting your Interface 1000 to earth ground and then connecting the Faraday cage to the Interface 1000's floating ground (the black lead on the cell cable).

Electrical Transient Sensitivity

Your Interface 1000 Potentiostat/Galvanostat/ZRA was designed to offer reasonable immunity from electrical transients, including transients on the incoming AC Mains supply and Electrostatic Discharge. It has been tested for compliance with EN 61326:1998—*Electrical equipment for measurement, control, and laboratory use— EMC Requirements* describing acceptable limits for Electrical Transient susceptibility in Laboratory Test equipment. It should continue to operate when subject to the standard ESD and power line events defined in EN61326.

In severe cases involving transients beyond the limits tested in EN61326, the Interface 1000 could still malfunction as a result of electrical transients. If you are having problems in this regard, the following steps may help:

If the problem is static electricity (sparks are apparent when you touch the Interface 1000 or it's cables):

- Placing your Interface 1000 on a static control work surface may help. Static control work surfaces are now generally available from computer supply houses and electronics tool suppliers. An antistatic floor mat may also help, particularly if a carpet is involved in generating the static electricity.
- Air ionizers or even simple air humidifiers can reduce the voltage available in static discharges.

If the problem is AC power line transients (often from large electrical motors near the Interface 1000):

- Try plugging your Interface 1000 into a different AC power branch circuit.
- Plug your Reference into a power line surge suppressor. Inexpensive surge suppressors are now generally available because of their use with computer equipment.

Contact Gamry Instruments, Inc. if these measures do not solve the problem.

CE Compliance

The European Community has instituted standards limiting radio frequency interference emitted by electronic devices, setting limits for susceptibility of apparatus to RF energy and transient events, and mandating safety requirements. Gamry Instruments, Inc. has designed and tested the Interface 1000 to comply with these standards.

The relevant CE regulations include EN 61010 and EN 61326.

RoHS Compliance

The Interface 1000 has been built using lead free components and lead free solder. It is in compliance with the European RoHS initiative.

Chapter 2 -- Introduction

About this Manual

This manual covers the installation, safety, and use of the Gamry Instruments Interface 1000 Potentiostat/Galvanostat/ZRA.

This manual describes use of an Interface 1000 with Revision 6.0 (and later revisions) of the Gamry Framework software. It is equally useful when setting up a newly purchased potentiostat or modifying the setup of an older potentiostat for use with new software.

Chapter 1 was an in-depth discussion of safety issues. This chapter describes this manual and gives a brief overview of the Interface 1000 features. Chapter 3 contains Interface 1000 installation instructions. Chapter 4 describes cell cable connections and Chapter 5 describes the Interface 1000's Front and Rear Panels. Chapter 6 is a description of the electronics circuitry in the Interface 1000. Chapter 7 covers the difficult issues of potentiostat stability and approaches to prevent oscillation. Chapter 8 discusses the realities of low current, high impedance measurements.

You will find dry technical material such as specifications and connector pin-outs in the Appendices. Appendix E discusses heat generation in multiple potentiostat systems based on the Interface 1000 and makes recommendations for heat management.

This manual discusses software installation or software operation in some detail. The installation is written assuming installation using Revision 6.0 of Gamry's Framework software. Installation is also described in the Gamry's Quick-Start Installation Guide for USB Potentiostats.

Software support for the Interface 1000 is described in the Gamry Help system.

All Gamry Instruments applications running under the Gamry Framework control the Interface 1000 via a PSTAT object. See the Framework's Help for information concerning PSTAT objects and their functions.

About the Interface 1000

The Interface 1000 is a value oriented, research grade electrochemical instrument packaged in a small, easy to handle case. It works particularly well in systems with multiple instruments connected to one computer. It offers measurement capabilities similar or superior to those of instruments that are more than ten times its size and weight and more than three times its price.

The Interface 1000 can operate as a potentiostat, a galvanostat, or a ZRA (zero resistance ammeter).

Interface 1000 features include:

- 9 decade current auto-ranging,
- electrical isolation from earth ground,
- current interrupt iR compensation, and
- both analog and digital filtering.

A sine wave generator on the Interface 1000 allows its use for accurate impedance measurements at frequencies up to 1 MHz. EIS performance is excellent for both high impedance systems (such as painted metals) and low impedance systems (such as low ESR electrical double layer capacitors.)

Data can be acquired at frequencies up to 100000 points per second.

A unique DSP (Digital Signal Processing) data acquisition mode allows the Interface 1000 to reject noise, from the instrument itself, from the electrochemical cell, and from the lab environment. In many cases where other instruments require a cell in a Faraday shield to make quiet measurements, the Interface 1000 can be used with the cell exposed on a bench top.

The Interface 1000, like all Gamry potentiostats, requires a computer for its use. Unlike our older potentiostats, the Interface 1000 interfaces to the computer through a USB connection. The USB connection has become truly universal, with USB ports found on all modern computers. Gamry Windows based software currently supports up to 16 Gamry Potentiostats connected to one computer. A system can include a mixture of Gamry Reference and Interface Family instruments.

The Interface 1000 is isolated from earth ground. It can therefore be used to make measurements on cells that contain an earth grounded metal. A few of the many examples of such systems are autoclaves, large metal storage tanks, stress apparatus, and capillary electrophoresis detectors.

Software and Applications

The Interface 1000 supports all Gamry electrochemical applications software, including Gamry PWR800 Electrochemical Energy Software. The PWR800 was not supported on several older, low cost instruments.

The Interface 1000 should be particularly useful in laboratories where high test throughput is required. Multiple Interface 1000's can be used to configure flexible MultEchem systems, where the number of potentiostats in each system can vary as needed.

For example, a dozen Interface 1000s in a lab can be used as one eight-potentiostat MultEchem system and four stand alone systems one week then used as two six-potentiostat MultEChem systems the next week.

Typical applications for the Interface 1000 include:

- Corrosion testing,
- Evaluation of protective coatings and paints,
- Research in electrochemical storage and conversion,
- Battery and electrochemical capacitor evaluation,
- Bio-electrochemical testing,
- Electrochemical sensor development.

MultEChem Systems

The Interface 1000 can form several different types of MultEchem multiple potentiostat systems.

In one type of system, multiple Interface 1000 units are simply stacked on top of each other. The Interface 1000 chassis was designed for easy and secure stacking. The rubber feet on the bottom of one instrument mate with indentations in the top of the instrument below.

In this type of system, each Interface 1000 is powered by an individual AC Adapter, which in turn can be powered by a multiple output AC power strip. The multiple USB connections for the system can be obtained from an inexpensive commercial USB hub.

In a more formal, less cluttered system, multiple Interface 1000 units can be added to a special Gamry supplied rack called the Interface Power Hub. This smart rack arranges the units side-by-side and takes care of power and USB connections. Individual units can still be easily added and removed as required.

In some multiple potentiostat systems, users want synchronized operation of several potentiostats. This is often desirable when multiple units are connected to one electrochemical cell. Examples of this include ring-disk systems, series connected laminar flow generation-detection systems, localized EIS and electrochemical microscopy.

A special synchronization port (Sync port) on the rear of each Interface 1000 allows one Master instrument to control the clocks and data acquisition timing of multiple Serf instruments. The Master can even generate sine waves used for EIS experiments and the Serfs can acquire very accurate EIS data derived from the Master's excitation waveform. Additional information concerning synchronization cables can be found in Appendix C.

Heat can be an issue in a MultEchem System. This subject is discussed in detail in Appendix E of this manual.

Front Panel Personalization

The Interface 1000 supports a flexible labeling scheme for identifying potentiostats in a multiple potentiostat (MultEChem) system. A clear window in the plastic overlay on the Interface 1000's front panel allows user defined identification of each potentiostat in a system.

Every Interface 1000 is shipped with its serial number in this label location. More user friendly labels can also be displayed, such as Pstat1, Pstat2, Pstat3. Whimsical names such as "Rusty Dog" can also be displayed in this area. See Chapter 4 for more details.

Notational Conventions

In order to make this manual more readable we have adopted some notational conventions. These are used throughout this manual and all other Gamry Instruments manuals:

- Numbered lists. A numbered list is reserved for step-by-step procedures, with the steps always performed sequentially.
- Bulleted list. The items in a bulleted list, such as this one, are grouped together because they represent similar items. The order of items in the list is not critical.
- File names and folders. Inside paragraphs, references to computer files and Windows folders will be capitalized and placed within quotes, for example: "C:\MYGAMRYDATA\CV.DTA" and "GAMRY5.INI".

The term Interface 1000 is generally written in place of the more correct but awkward term Interface 1000 Potentiostat/Galvanostat/ZRA.

Chapter 3 -- Installation

This chapter of the Gamry Instruments Inc. Interface 1000 Operator's Manual covers normal installation of the Interface 1000. We assume the Interface 1000 is installed as part of a Gamry Framework based electrochemical measurement system containing a Microsoft Windows™ compatible computer.

Figure 3 - 1
Front View of an Interface 1000



Initial Visual Inspection

After you remove your Interface 1000 from its shipping carton, you should check it for any signs of shipping damage. If any damage is noted, please notify Gamry Instruments, Inc. and the shipping carrier immediately. Save the shipping container for possible inspection by the carrier.

Warning

The “reinforced insulation” that keeps the operator from accessing the “hazardous live” voltages in the Interface 1000 can be rendered ineffective if the Interface 1000 is damaged in shipment. Do not operate damaged apparatus until a qualified service technician has verified its safety. Tag a damaged Interface 1000 to indicate that it could be a safety hazard.

Warning

If the Interface 1000 is taken from a cold location (for example outdoors in winter conditions) to a warm humid location, water vapor could condense on the cold surfaces inside the Interface 1000, possibly creating a hazardous condition. The “reinforced insulation” that keeps the operator from accessing the “hazardous live” voltages in the Interface 1000 can be rendered ineffective if the Interface 1000 has condensed water inside its case. Before connecting power to a “cold” Interface 1000, allow at least one hour for the Interface 1000 to warm at room temperature.

Physical Location

You normally locate your Interface 1000 on a flat workbench surface. You will want to have access to the rear of the instrument because some cable connections are made from the rear. The Interface 1000 is generally operated in a flat position (see Figure 3-1). Operation in other positions is possible as long as you insure that air movement through the chassis is not restricted.

Caution

Do not block the airflow into or out of the Interface 1000 chassis. The Interface 1000 will enter a power down state if it becomes over heated. If this occurs during data acquisition, experimental data could be lost.

If you do place your Interface 1000 within an enclosed space, make sure that the internal temperature within that space does not exceed the 45°C ambient temperature limit of the Interface 1000. Be particularly careful if a computer or other heat dissipating equipment is mounted in the same enclosure as the Interface 1000.

The Interface 1000 has not been designed for outdoor use.

Computer Requirements

Before you connect an Interface 1000 to a computer you must make sure that your computer meets these simple requirements.

- A computer based on one of the x86 family of Intel microprocessors or a 100% compatible processor from another vendor,
- One of the following Operating Systems: Microsoft® Windows XP Service Pack 3, Windows Vista®, or Windows 7 is required. Both 32-bit and 64-bit versions of these Operating Systems are supported. (See the Gamry website “www.gamry.com” if you have a newer edition of Windows),
- A USB port that supports Full Speed (12 Mbits/second) or High Speed (480 Mbits/second) USB transfers. It must be compatible with Revision 1.1 or Revision 2.0 of the USB specification.

Quick Start Guide for System Installation

Your shipment should have included a short document entitled: **Quick-Start Installation Guide - USB Potentiostat**. It contains the latest instructions for installing Gamry hardware and software onto a computer system. If this document is missing, the following information should be sufficient for you to install the Gamry Framework Software and Gamry Potentiostat onto your computer.

Software Installation

The Interface 1000 is compatible with the Windows Plug & Play configuration system. Like most Plug & Play hardware, it is best if you install the software for the Interface 1000 before you install the potentiostat hardware.

Gamry Software Setup program will normally start automatically when you place the Gamry Instrument’s Software CD (or Gamry Instrument Software Flash Drive) into your computer.

If you have inserted the Gamry CD or Flash Drive into your computer and the Gamry Setup program does not start automatically:

- 1) Navigate to the root folder of the device containing the Gamry Software (CD or Flash Drive) or to a Windows folder containing the Gamry Software.
- 2) Run the program called Autorun.exe found in this folder.

If you do not know how to navigate to the Gamry Installation device, consult your local computer expert or network administrator or email techsupport@gamry.com.

Autorun.exe will run a Setup program. In most cases, you can choose the default choices or the most obvious choices on all screens shown during the Setup process.

When the "Select Features" screen appears you will see a list of applications (eg DC105, PHE200, ESI300). Make sure that you select all the applications that have been purchased with your system.

Reboot your Computer after Software Installation

You should reboot your computer once the Gamry Setup program is done. The Setup program will normally offer you the opportunity to do so. USB device drivers are usually loaded when Windows boots up. Following Setup, you may not be able to use your Interface 1000 until the drivers are loaded.

Note

Device Driver Installation may not occur until a while after the Windows Desktop screen appears. On a slow computer, or a busy computer with lots of applications, the delay before driver installation can be a minute or more.

Power Cord and Power Connection

The Interface 1000 does not plug directly into the AC mains supply. Instead, the mains are connected to an external power supply, which supplies a regulated 48-volt DC output. This regulated DC is then connected to the DC power input jack on the rear of the Interface 1000.

The external power supply provided with the Interface 1000 is rated for operation from 100 to 240 V_{AC} at frequencies from 47 to 63 Hz. It should therefore be useable worldwide.

The Interface 1000 external supply is normally supplied with a line cord suitable for use in the United States. In other countries, you may have to replace the line cord with one suitable for your electrical outlet type. You must always use a line cord with a CEE 22 Standard V (IEC 320 C13) female connector on the apparatus end of the cable. This is the same connector used on the US standard line cord supplied with your Interface 1000.

The DC output cord from the external power supply plugs into the DC Power input jack on the rear panel of the Interface 1000 (see Figure 3 - 2).

Note

The output cable from the external power supply ends in a 3-pin miniature power DIN male connector. This DIN connector cannot be plugged into either of the other DIN connectors on the Interface 1000. Improper connection is therefore unlikely.

Figure 3 - 2
Rear Panel of the Interface 1000

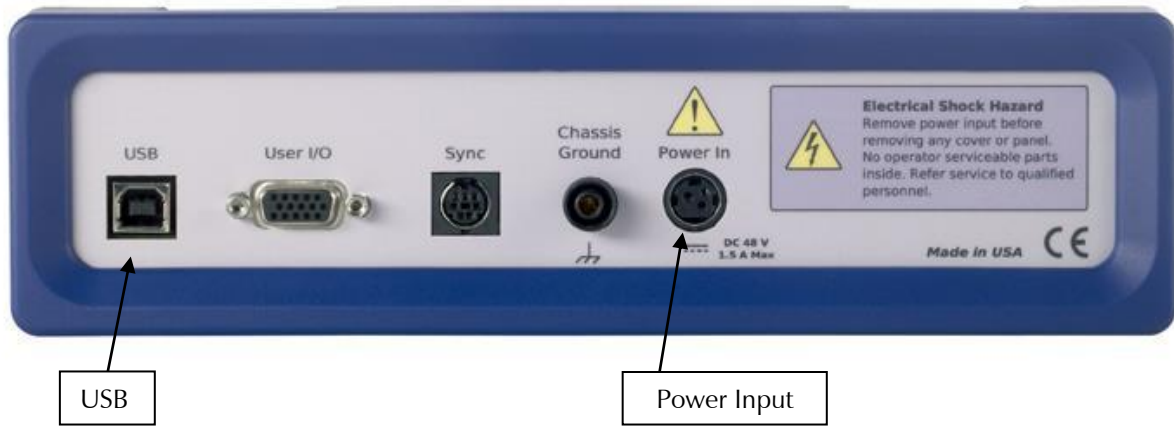

Power Up Test

Before you make any other connections to your Interface 1000 you should check that the Interface 1000 is at least nominally functional.

After connecting DC power to the Interface 1000, turn on the Power switch on the front panel of the Interface 1000 (see Figure 3 - 1).

Watch the Power LED as the Interface 1000 powers up. It flashes slowly four or five times (depending on the amount of software loading), then glows a steady blue. This process could take as long as 15 seconds. The Interface 1000 fan runs at low speed once the Power light stops flashing. If you do not see four or five blinks and then a steady blue color, see Appendix D for a table of blink codes.

The status of the other LED indicators is not important at this time.

If the power LED goes on, then turns off and stays off, the Interface 1000 is not working properly! If this power-up test fails, contact Gamry Instruments or your local Gamry Instruments representative as soon as possible.

If the Power LED continues to flash after 30 seconds, the instrument could be malfunctioning or the instrument could be over-heated. Make sure the Framework Instrument Manager is not causing the flashing (page 3-9). Check that the air-flow through the chassis is not restricted. If airflow looks okay and the Power LED continues to flash, contact Gamry Instruments (techsupport@gamry.com) or your local Gamry Instruments representative as soon as possible,

USB Cabling

The Interface 1000 connects to the computer using a filtered High Speed USB A/B cable. A suitable cable was shipped with your Interface 1000. The replacement cable is Gamry Part Number 985-131.

An A/B USB cable has different connectors on each end. The end with a wider, rectangular shaped connector plugs into a USB port on your computer (or a similar port on a USB hub). The end with a nearly square connector plugs into the USB port on the Interface 1000 (see Figure 3 - 2).

The USB connection can be "hot-plugged". This means both the computer and the Interface 1000 can be powered-up before the USB cable is plugged in. Unlike many other instrument system connections, you need not power down the system before plugging in the USB.

You can also safely remove the USB cable without powering down the Interface 1000 and your computer. Be aware, however, that this may have undesirable consequences if the system is currently taking data or performing an electrochemical experiment.

Multiple Potentiostat Systems

Gamry's current Framework software (Revision 6.0) allows a computer to operate up to 16 Gamry Instruments potentiostats simultaneously. The 16 potentiostats can include Interface 1000s and Gamry Reference family instruments.

A system with multiple Interface 1000s just needs them all plugged into the computer via a High Speed USB hub. We do not recommend using bus-powered hubs to expand your USB network: an externally powered USB hub is required. Suitable hubs are available at most computer retailers.

Gamry's Interface Power Hub is an especially convenient tool for organizing a system containing up to eight Interface family instruments. It includes a 10 port USB hub and 48 volt power distribution in a rack designed to hold the instruments. Unlike most instruments with multiple potentiostats in one box, the Interface instruments in an Interface Power Hub are easily removed for temporary use elsewhere in you lab.

Contact our home office or your local Gamry Instruments representative if you need assistance configuring a system containing an Interface 1000 and different Gamry potentiostats.

Heat can be an issue in a multiple potentiostat system. This subject is discussed in detail in Appendix E of this manual.

Cell Cable Installation

The Cell Connector is a 25-pin female D connector on the front of the Interface 1000 (see Figure 3 - 1).

All Gamry standard cell cables have a 25-pin D-connector on one end and a number of leads terminated with banana plugs on the other. The D-connector end of the cable is connected to the Cell Cable port on the front of the Interface 1000. The knurled screws on this cable should always be used to hold the cable in place.

A wide variety of cell cables are available for the Interface 1000. These include shielded cables in various lengths and special cables for use in EIS systems where very low impedances must be measured. The Interface 1000 can automatically detect which Gamry Instruments cable is connected and the Gamry Framework software can then adjust the system performance for the characteristics of that cable.

Front Panel USB LED

The front panel USB LED provides a simple test of two aspects of normal Interface 1000 USB operation. It has three normal states:

- Unlighted, indicating that the USB cable is disconnected or the USB connection is disabled by the host computer,
- Solid Green, indicating that a valid cable connection has been made and the Interface 1000 USB processor is receiving power from the USB cable,
- Flashing Red or Yellow, indicating that valid USB messages are being transferred between the computer and the Interface 1000.

The flashing state will only be seen when Gamry Instruments application software is running.

1st Time Device Installation in Windows XP

When an Interface 1000 is first connected to a computer running Windows, the Windows Plug and Play Manager will see the new device, but it may be uncertain what device it is.

Note
These instructions presume you have already installed Gamry software.

Windows 7 Users: The dialog boxes in this section of the manual will not be displayed. Please skip to the next section of the manual, **Running the Framework** to continue the installation process.

Windows XP or Vista Users, the message that will appear is something like “New device found” or “Unknown USB device Detected”. The next screen looks something like this:

Figure 3 - 3
Welcome to the Found New Hardware Wizard



As shown in this Figure, do not choose to let Windows Update find the device driver that you need. The Windows Update web site has no knowledge of the Gamry Instruments Interface 1000.

Make sure you select **No, not this time**. After you select, **N**ext, you should see a screen that looks like this:

Figure 3-4
Install the Software Automatically

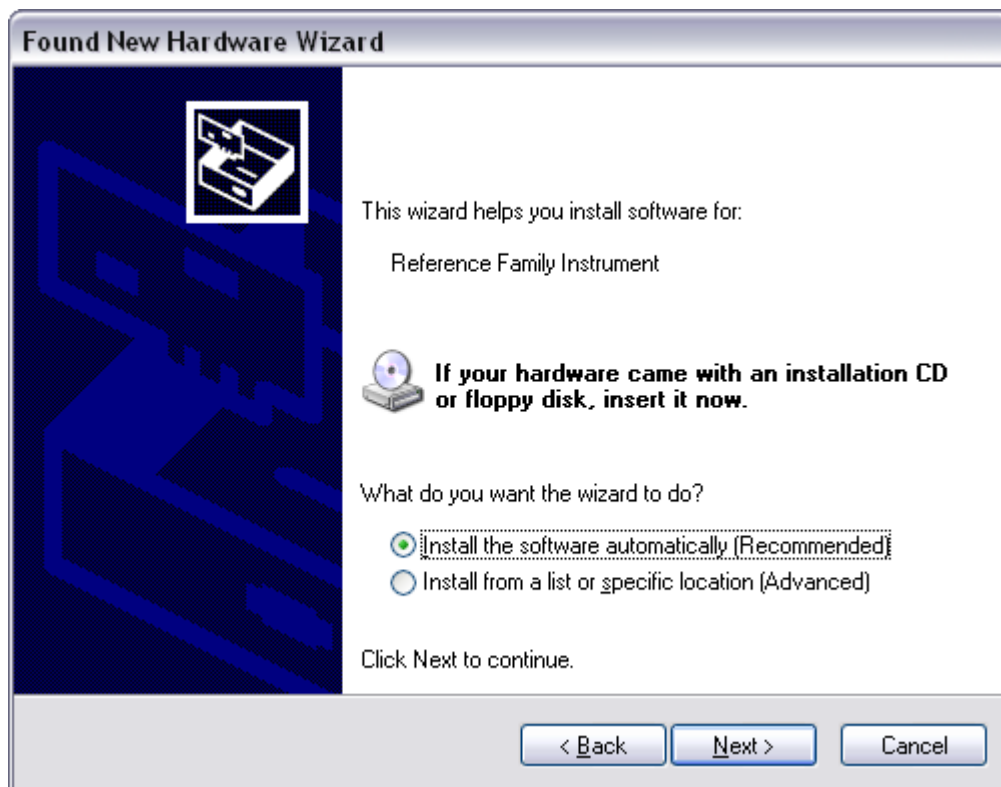

All Gamry device drivers are pre-installed on your computer disk drive during the software installation process. Select **Install the software automatically**, then select **Next**.

These messages will also be seen when an Interface 1000 instrument is moved to a new USB port. In this case, you can still select **Install the software automatically**, even if you do not have the Gamry Instruments CD. The driver that was previously installed on your computer's disk drive will be used.

The Windows Device Manger will locate and install the required files, which are already on your system.

Running the Framework

Regardless of your electrochemical application, Gamry recommends running the Gamry Framework after you install new Framework software or add a potentiostat to your system. The Framework Instrument Manager allows you to:

- Rename potentiostats,
- Calibrate potentiostats,
- Manage potentiostat firmware,
- Authorize Specific Applications for use with Specific Potentiostats

You run the Gamry Framework by clicking on the icon it installed on the Windows desktop. You can connect and power any Gamry potentiostats either before or after you start the Framework.

Framework Device Status Bar

By default, the Gamry Framework shows a Device Status Bar under its main menu: see Figure 3-5. If you don't see the Device Status Bar when you run the Gamry Framework, it has been disabled in the Framework **Options** menu.

Potentiostat Devices (instruments) that are connected to the computer appear on this bar. The round indicator associated with each device shows its status:

Green	The device is available to run experiments
Yellow	The device is currently running an experiment
White	The device is connected to the system, but is not usable. This is generally the result of a revision mismatch between the Framework software and the device's firmware. You can use the Framework Instrument Manager to fix the mismatch.

The screen capture below shows a Framework screen with three USB instruments connected.

Figure 3-5
Framework With Three Potentiostats and One Running Test

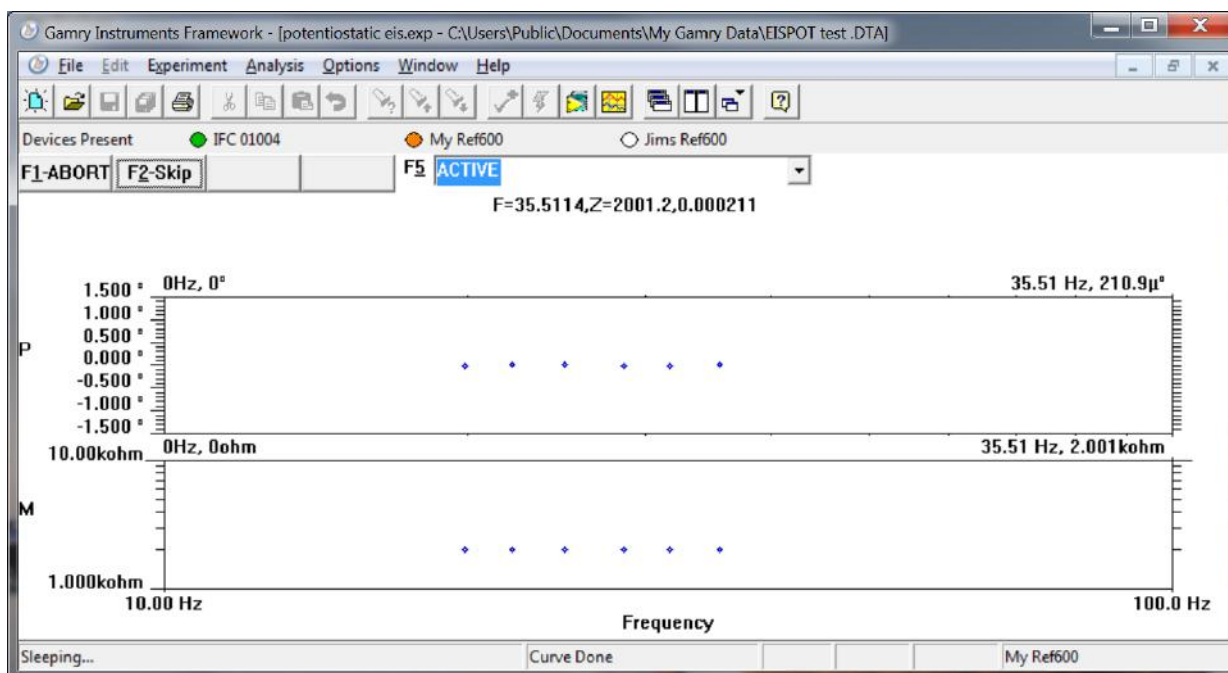

The Interface 1000 (IFC 01004) in this system is shown with a green indicator because it is installed and ready to run. The Reference 600 labeled My Ref600 has a yellow indicator because it is recording the EIS spectrum shown on the screen. The Reference 600 labeled Jims Ref600 has a white indicator, showing it is plugged in but cannot be used. This is an indication of obsolete firmware.

Gamry Instrument Manager

You can use Gamry's new Instrument Manager dialog box to make changes to the configuration of your Interface 1000 system. This dialog box is accessed through the **Options** menu in the Gamry Framework.

The Instrument Manager is used to:

- Rename potentiostats
- Delete potentiostats that are not currently connected to the computer
- Select the order in which potentiostats appear in menus
- Authorize potentiostat use with applications packages
- Update firmware within potentiostats

You run the Instrument Manger by selecting **Options, Instrument Manager...** on the Framework Menu.

Figure 3-6 shows the Instrument Manager dialog box for the three potentiostat Framework session shown in the previous section.

Figure 3-6
Instrument Manager Dialog Box

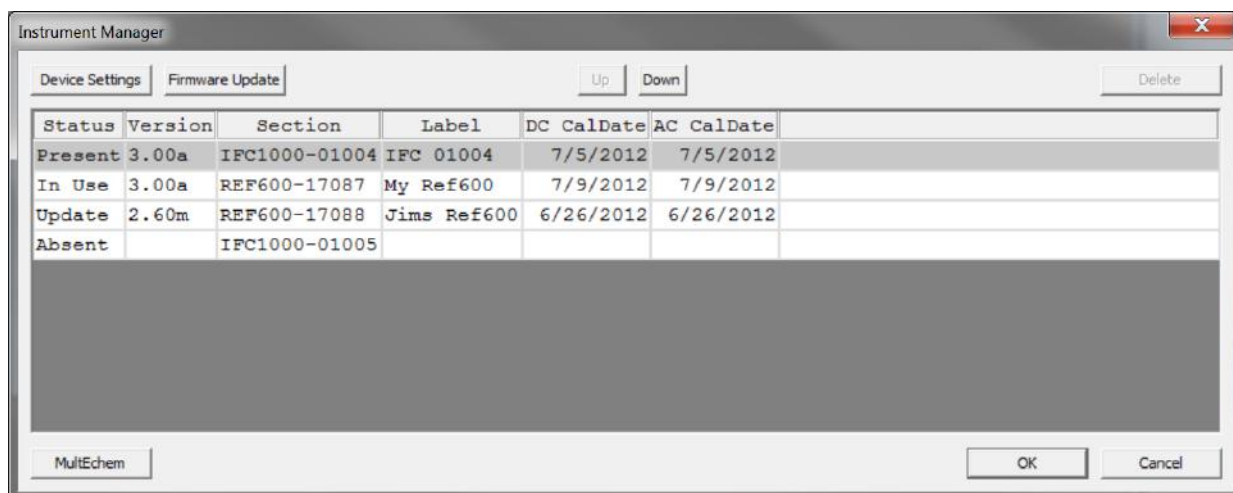

Each Gamry potentiostat in the system appears on a separate row. All Gamry Instruments potentiostats that are known to the system are displayed in the Instrument Manger. An instrument is selected by clicking anywhere within that row for that instrument. Selecting an instrument that is connected and idle will blink its Power LED.

The buttons on the right side of the dialog box change depending on which instrument is selected. Some buttons are inappropriate for some instruments.

The Status column tells you the whether each instrument is available and usable by the Framework. Possible status conditions are:

Present	The instrument is connected, powered, and available for use.
Absent	The instrument was connected in the past but is currently not connected or not powered. Instruments with this status can be deleted from the system
In Use	The instrument is currently running a Framework experiment.
Update	The instrument is connected and powered, but cannot be used to run experiments. Its current firmware revision is not compatible with the current Framework revision. You can update the instrument's firmware by selecting this instrument and selecting Firmware Update .

You can delete an Absent instrument by selecting **Delete** when an instrument is selected. Deleting an instrument simplifies the Instrument Manager dialog box. It has little effect otherwise; the deleted instrument can be reconnected later.

When you setup an experiment, you will need to select the potentiostat used to run the test. The instruments will appear in the order shown in the Instrument Manager, with the device in the top row displayed first. The **Up** and **Down** buttons allow you to move a device in the dialog box and change the order in which devices are displayed.

Authorization Codes and Label

If you purchase additional Gamry application software or you need to make a correction to your authorization codes, you can do so using the Windows Device Manager or the Framework Instrument Manager. The Gamry Framework Application Software must be closed before you can use the Device Manager to make changes.

The dialog box used to enter authorization codes also allows you to change the Label for your device. The first step in making changes is to run the Instrument Manager or Device Manager and select the appropriate device, as discussed in the Device Manager and Instrument Manager discussions above. Once you have selected the appropriate device select **Properties** or **Device Settings** and you will see a screen that looks like Figure 3-7:

Figure 3-7
Device Settings Tab



This was the Instrument Manager **Device Settings** dialog box for the second potentiostat in the system described above. You can enter or edit any of the authorization codes or Label for the device by clicking on the appropriate edit box and entering the information. In the Figure above, the default label has been changed to a friendly name - My Ref600.

To enter an authorization code, simply click on the Add button. A dialog box will appear as shown in Figure 3-8. You enter the package name, such as "EIS300", followed by the 10 digit authorization code.

Figure 3-8
Enter an Authorization Code

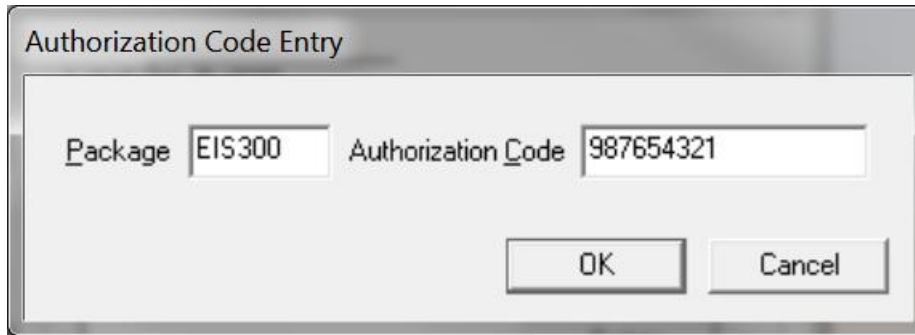

Press **OK** when you are finished.

On occasion you may have to change the USB port used to connect the Interface 1000 to your computer. The Windows Device manager will interpret an Interface 1000 on a new USB port as a new Interface 1000.

Firmware Update

Your Interface 1000 was shipped with the latest version of all its firmware. From time to time, Gamry makes changes to the instrument's Firmware code, and a firmware update will be required to make use of the new or improved code.

There are three separate firmware images that can be field updated on your Interface 1000. The first is the Instrument Firmware. This is the program that handles most of the functionality of the Interface 1000. The second is the Communications Firmware. This program handles the USB communications between your Interface 1000 and the host computer. The third is the PLD firmware, which users should only change following instruction by a Gamry Instruments representative.

Appropriate update files (firmware images) can be obtained from the Gamry Instruments website at www.gamry.com. Download the file containing the new image and save it onto your computer's hard disk. Alternatively, every Gamry Software CD (or Gamry Software Flash Drive) contains a firmware folder that contains firmware files compatible with that CD's Framework revision.

You can initiate the Firmware Update process using the Framework **Options, Instrument Manager...** command or using the Windows Device Manager. The Instrument Manager is the preferred method.

To update any of the Firmware, you must first select the appropriate device in the Instrument Manager, as discussed in the Device Manager section. Once you have selected the appropriate device, click **Firmware Update** and you will see a screen that looks like Figure 3-9:

Figure 3-9
Firmware Update Tab

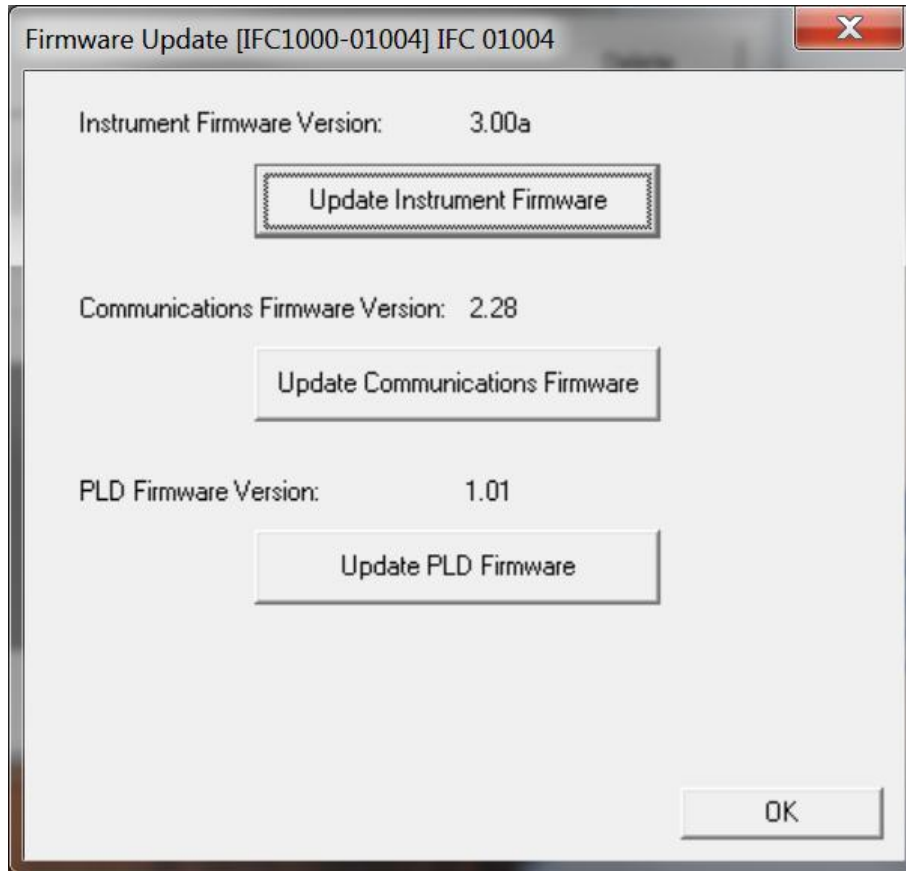

Depending upon which code you wish to update, click on **Update Instrument Firmware**, **Update Communications Firmware**, or **Update PLD Firmware**. You will then be prompted for a file. Navigate to the file's location (on the Gamry software CD or on your computer's hard drive) and then press **Open**. The update procedure will begin. A status bar shows the progress of the update. The USB indicator on the Interface 1000 should also turn red during the procedure. Once the update is successful, press **OK** and your Interface 1000 will be ready for use.

Once again, appropriate update files can be obtained from the Gamry Instruments website at www.gamry.com. Should you encounter a problem updating the firmware in your Interface 1000, please contact Gamry Instruments for assistance.

Interrupting a firmware update can cause a catastrophic failure of your system. Do not turn off the Interface 1000, do not unplug the USB cable, and do not stop the host computer operation when the USB LED is a steady red color.

Caution

Do not interrupt a firmware update that is in progress. An incomplete update can render an Interface 1000 inoperable until it is returned to Gamry for reprogramming.

Calibration

You should calibrate each potentiostat installed in your system. A calibration script is provided with the Gamry Framework.

The calibration for the Interface 1000 has been divided into two sections: DC Calibration and AC Calibration. The calibration procedure is accessed via the **Utility** selection on the Framework's **Experiment** pull down menu.

Separate AC Calibration for Each Interface 1000 Cable Type

The Interface 1000 now recognizes the type of cable connected to its cell connector. It maintains a separate AC calibration table for each type of cable. The Gamry Framework will not let you use AC calibration data recorded using a 60 cm shielded cable for experiments run using a Twisted Pair cable optimized for low impedance EIS measurements.

DC and AC Calibration

These two procedures use an external resistive dummy cell.

CAUTION

The standard Interface 1000 calibration calls for an external resistive dummy cell. Your Interface 1000 was shipped with a Universal Dummy Cell 4, which includes a 2 k Ω , 0.05% accurate resistor in the position marked "Calibration". After calibration, please place this dummy cell in a safe place where you can find it if your unit requires recalibration.

If you do need to recalibrate and you cannot find your Universal Dummy Cell 4, you can perform DC Calibration using a different 2 k Ω resistor. Its wattage is unimportant. Some performance checks in the calibration process may fail if the resistor's inaccuracy exceeds 0.2% (4 Ω).

We do not recommend AC Calibration with any resistor other than the one on the Universal Dummy Cell 4. The Universal Dummy Cell 4 was designed to separate the working electrode leads from the counter and reference electrode leads. If you perform AC Calibration without adequate separation between these leads, you will see phase shift in your high frequency EIS data. 1.4 pF of stray capacitance across a 2000 Ohm resistor causes a 1° phase shift at 1 MHz.

Potentiostat calibration is only required infrequently. You should recalibrate your Interface 1000 under the following circumstances:

- It has been about one year since your last calibration.
- Your potentiostat has been serviced.
- You notice breaks or discontinuities in the data curves recorded with your system.
- The system is being run in an environment that is very different from the previous operating environment. For example, if the Interface 1000 was calibrated at 15 °C and you are now operating it at 30 °C, you should recalibrate.

Figure 4-10
UDC4 With Leads Attached for Calibration

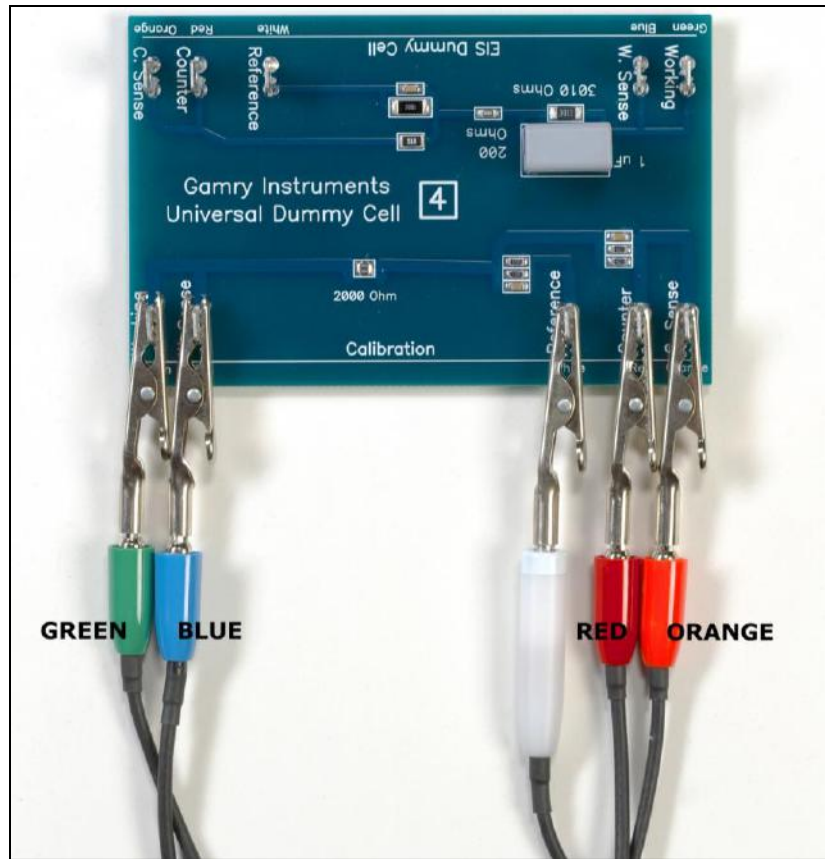

The Interface 1000 Personalization Label

Introduction to the Interface 1000 Personalization Label

Modern electrochemical testing often involves replicate tests designed to measure and/or minimize the effect of irreproducibility in the measurements. As an example, most electrochemical corrosion tests use a minimum of 3 replicate samples and cells. Corrosion rate variability of $\pm 25\%$ sample to sample is quite common.

Multiple potentiostat systems are often used to speed up the testing process. If the multiple potentiostats can be randomly located in the lab, potentiostat identification can be a problem. The user may need to know "Is the potentiostat on the left of my computer the 2nd or 3rd potentiostat in the system"?

The Interface 1000 includes a personalization label that makes each unit visually unique. This allows you to know exactly which potentiostat will be used for each test. By default, each Interface 1000 ships with a label containing the instrument's Serial Number (S/N XXXXX). Other labels are easily placed in the instrument's Personalization Label area. In a system containing 8 potentiostats, the potentiostats might be labeled **Pstat 1, Pstat 2, Pstat 3, ... Pstat 8**.

Simple paper labels are inserted in an area behind the clear plastic outer layer of the front panel. The paper is behind the plastic, so it is not affected by the lab environment. Best of all, the labels can be edited and printed so personal labels, like **Bob's Stat** are also possible.

Label Sheet Provided With Each Interface 1000.

Every Interface 1000 is shipped with a preprinted label sheet containing:

- Instructions on how to change the label
- Several copies of the default label - the instrument's Serial Number
- The first eight letters of the Greek alphabet - Alpha through Theta
- The eight planets in the solar system - Mercury through Neptune
- Several blank white labels
- Pstat 1 through Pstat 16 on a blue background
- Pstat 1 through Pstat 8 on a red background

Any of these labels can be cut from the sheet and inserted as the Interface 1000 Personalization Label. The white labels are provided to allow the user to hand write a label.

Label Files on the Gamry Website

If you want a professional looking label not found on the label sheet provided with your Interface 1000, the label files on the Gamry website www.gamry.com can be useful. These files can be found in the Downloads tab of the Interface 1000 Product page. There are two files in Microsoft Excel™ format. One file is formatted for American/British 8 1/2 x 11 inch paper and the other is formatted for Metric A4 paper.

After you download one of these files, you can open and edit it. If you don't have Microsoft Office on your computer, free Excel compatible spreadsheet programs are available on the Internet. These free programs will probably work well for simple edits and printing.

Each label is contained in one Excel cell. In addition to changing the text in a cell you can change the font, the font size, and colors of the cell. You should not change the cell's size. The area toward the right side of each cell appears in the Interface 1000 front panel.

Once you are happy with your edits, you can print the Excel file on any color printer. A heavy grade of paper is preferred, although labels printed on standard weight copier, inkjet or laser printer paper have been used. The default instrument label sheet was printed on 120 g/m² paper (the US/British equivalent is 32 pound bond paper).

Procedure to Change a Label

Follow these steps to change a label.

Figure 3-9
Removing the Front Bezel

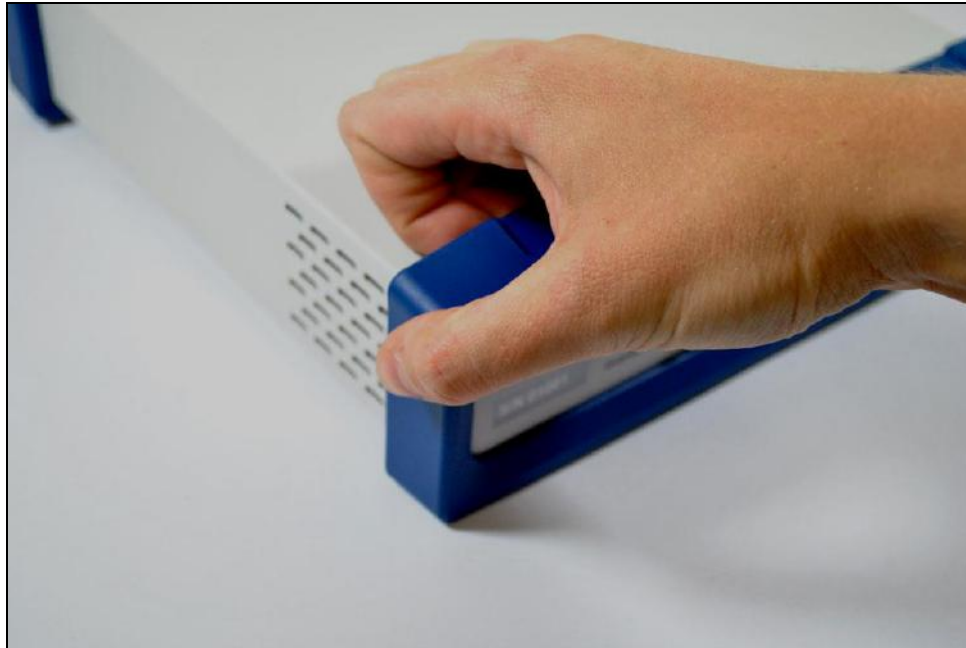

To change a label:

- 1) If you are making a custom printed label, edit the Excel file and print a label sheet as described above. If you are using the Gamry supplied label sheet, identify the location on the sheet where the new label is found.
- 2) If you are handwriting on a blank label, do it now.
- 3) Use scissors to cut out the new label - Cut white labels on the black lines.
- 4) Power down the Interface 1000 that is getting the new label.
- 5) Remove the instrument's rubber front bezel (the rubber frame around the front panel). Tools should not be required. See Figure 3-9.

You grip the bezel as shown in the Figure and pull the bezel away from the front panel. Some force will be required. Don't worry about ripping the bezel - they are quite rugged. There is a 5 mm ear on either side of the instrument that keeps the bezel in place.

- 6) Your Interface 1000 should now look like Figure 3-10 which shows the instrument with the front bezel removed. Notice the blue tab on the left side on the instrument. This is part of the old label - blue on the instrument in the photo.
- 7) Pull gently on the paper tab on the left side of the front panel to remove the existing label. You need to pull out about 5 cm of label.
- 8) Insert the new label in the same spot as the old label. The text should face the front of the instrument. A small tab of paper will extend beyond the instrument's front panel.

- 9) Examine the new label's position in the Interface 1000 Front Panel. Adjust the label if needed.
- 10) Replace the rubber bezel. Make sure that the foot side of the bezel is toward the bottom of the instrument.
- 11) You will need to rename the Interface 1000 in the Gamry Framework to match the new label. You can do this using the Framework **Options, Instrument...** dialog box. In the resulting Dialog Box, select the device you want to rename and then select the **Device Settings...** button.

Figure 3-10
Instrument with Bezel Removed - Label Tab Seen



Chapter 4 -- Cell Connections

Normal Cell Connections

Each Interface 1000 in your system was shipped with a standard, shielded cell cable. The Gamry part number for this cable is 985-00071. It is a 60 cm complex cable with a 25-pin D type connector on one end and four banana plugs and two pin jacks on the other end.

In some cases, your system may also include a special purpose cell cable. The special purpose cell cable will include documentation describing its use.

The 25-pin male end of the standard cell cable connects to the Interface 1000's front panel Cell Connector.

You should always screw the cell cable into place since this cable can fall off the unit. This can be disastrous if it occurs during an experiment.

The other end of the cell cable terminates in a number of banana plugs and two pin jacks. Each termination comes with a removable alligator clip. Table 4-1 identifies each terminal of the cable.

Table 4-1
Cell Cable Terminations - Potentiostat and Galvanostat Modes

Color	Type	Name	Normal Connection
Blue	Banana Plug	Working Sense	Connect to working electrode
Green	Banana Plug	Working Electrode	Connect to working electrode
White	Pin Jack	Reference	Connect to reference electrode
Red	Banana Plug	Counter Electrode	Connect to counter electrode
Orange	Banana Plug	Counter Sense	Used in ZRA mode - connect to counter electrode
Black	Pin Jack	Floating Ground	Leave open or connect to a Faraday shield

Connect both the blue and green cell leads to the working electrode. The working electrode is the specimen being tested. The blue banana plug connection senses the voltage of the working electrode. The green working electrode connection carries the cell current. The working electrode may be as much as 150 mV above the circuitry ground (Floating Ground).

Connect the white pin jack to the cell's reference electrode, such as an SCE or Ag/AgCl reference electrode. The measured cell potential is the potential difference between the blue and white cell connectors.

Connect the red banana plug to the counter or auxiliary electrode. The counter electrode is usually a large inert metal or graphite electrode. The counter electrode terminal is the output of the Interface 1000 power amplifier.

The orange lead is only used in ZRA mode where it senses the counter electrode potential (see following section). Automatic switching to ZRA mode is possible if this lead is connected to the counter electrode. If you will not be using ZRA mode, this lead can be left open as long as you insure that it will not short against any other electrode.

The black pin jack is connected on the Interface 1000 end to Floating Ground. This is the circuitry ground for the analog circuits in the Interface 1000. In most cases, this terminal should be left disconnected at the cell end. When you do so, take care that its metal contact does not touch any of the other cell connections.

If your cell is a typical glass laboratory cell, all of the electrodes are isolated from earth ground. In this case, you may be able to lower noise in your data by connecting the Interface 1000's Floating Ground to an earth ground.

A binding post on the rear panel of the Interface 1000 is provided for this purpose. A water pipe can be suitable sources of earth ground.

Caution

If any electrode in your cell is at earth ground, you must not connect the Interface 1000 chassis to earth ground. Autoclaves, stress apparatus, and field measurements may involve earth grounded electrodes.

Warning

Make sure that your earth ground connection is made to a legitimate source of earth ground. Consult a qualified electrician if you are uncertain how to obtain an earth ground. Connecting the Interface 1000 to an incorrect and unsafe voltage can create a safety hazard (see Chapter 1 for details).

If you are measuring very small currents, you may find that a metal enclosure completely surrounding your cell (a Faraday shield) significantly lowers measured current noise. This Faraday shield should usually be connected to both earth ground and Floating Ground. The Floating ground on the black cell lead is a convenient source of ground.

If any electrode in your cell is connected to earth ground, you should only connect your Faraday shield to the black cell lead (Floating Ground).

The alligator clip on any cell connection can be removed to access the underlying banana plug or pin jack. If you need to permanently change the terminations on your cell cable, feel free to remove the banana plugs and replace them with your new termination. Resistors in the old termination must be retained. Gamry Instruments can also provide additional standard or special cell cables.

In either potentiostatic or galvanostatic mode, if you do not have a reference electrode in your cell, the reference lead can be connected to the counter electrode for a two electrode experiment. The potential reading will be the difference between the counter electrode and the working electrode.

ZRA Mode Cell Connections

The Interface 1000 can function as a precision Zero Resistance Ammeter (ZRA). It maintains two metal samples at the same potential and measures the current flow between the samples. It can also measure the potential of the samples versus a reference electrode.

The cell cable connections for ZRA mode are shown in Table 4-2. Note that the connections are very similar to those for the potentiostat and galvanostat modes. A second working electrode is substituted for the counter electrode and the Orange Counter Sense lead must be connected.

Table 4-2
Cell Cable Connections for ZRA Mode

Color	Type	Name	Normal Connection
Blue	Banana Plug	Working Sense	Connect to metal sample #1
Green	Banana Plug	Working Electrode	Connect to metal sample #1
White	Pin Jack	Reference	Connect to a reference electrode
Red	Banana Plug	Counter Electrode	Connect to metal sample #2
Orange	Banana Plug	Counter Sense	Connect to metal sample #2
Black	Pin Jack	Floating Ground	Leave open or connect to a Faraday shield

The counter sense and the working sense lead are each connected to different metal samples. In the ZRA mode the Interface 1000 is normally programmed to maintain zero volts between these leads. It therefore maintains the two metal samples at the same voltage.

The white pin jack on the cell cable is normally connected to a reference electrode. The potential between this lead and the working sense lead is reported as the cell potential.

In ZRA mode, if you don't have a reference electrode in your cell, we recommend that you connect the white reference lead to the working electrode. In theory, the measured potential will be exactly zero when this is done. In practice, A/D noise and offset will create a small potential signal with a value very close to zero.

Membrane Cell Connections

The Interface 1000 can be used with membrane cells. In this type of cell, a membrane separates two electrolyte solutions. Two reference electrodes are used - one in each electrolyte. Each electrolyte also contains a counter electrode. The Interface 1000 controls the potential across the membrane. Table 4-3 shows the cell connections used with a membrane type cell.

Table 4-3
Cell Cable Connections for a Membrane Cell

Color	Type	Name	Normal Connection
Blue	Banana Plug	Working Sense	Connect to reference electrode #1
Green	Banana Plug	Working Electrode	Connect to counter electrode #1
White	Pin Jack	Reference	Connect to reference electrode #2
Red	Banana Plug	Counter Electrode	Connect to counter electrode #2
Orange	Banana Plug	Counter Sense	Leave open (only needed in ZRA mode)
Black	Pin Jack	Floating Ground	Leave open or connect to a Faraday shield

Note that reference electrode #1 and counter electrode #1 must be on one side of the membrane and reference electrode #2 and counter electrode #2 must be on the other side.

Chapter 5 -- Panel Indicators and Connectors

Note that the Interface 1000 uses three DIN connectors for connections to external devices. The three DIN connectors all have different numbers of pins and physical sizes, so the cables used in them cannot be interchanged and/or improperly connected.

Front Panel

The Interface 1000 front panel includes one power switch, two connectors and four back lighted LED indicators. It also includes a Personalization Area that allows for a unique visual name for each potentiostat in a multiple potentiostat system. Each of these will be discussed in turn. A picture of the Interface 1000 Front Panel can be seen in Figure 3 - 1.

Power Switch

The power switch is located on the far right side of the Interface 1000 Front Panel. It is a push-push switch – push once to turn the instrument on and push again to turn the instrument off. The switch's button latches – the button is closer to the Front panel when the instrument is on than when it is off.

Normally the Power LED will light when the Interface 1000 is powered – see the Power LED description below.

Normally, the DC Power is connected before the Power Switch is turned ON. However, no damage will occur if this switch is already in the ON position when the DC Power In cable is connected or when the AC power input is connected to the external power supply.

Be careful to avoid touching the Power Switch during normal instrument operation. Data will be lost if the instrument is accidentally powered off during an experiment.

Cell Connector

The Cell Connector is a 25-pin D type connector used to connect the Interface 1000 to an electrochemical test cell. It is normally used with a Gamry Instruments supplied cell cable.

In addition to the pins used for cell connections, the Interface 1000 Cell Connector also uses 5 pins to read a cell cable ID. Gamry software can compensate for the cell cable characteristics for optimal system performance, especially in EIS (Electrochemical Impedance Spectroscopy).

The cell connections are discussed at great length in Chapter 4. A pin-out of the cell cable connector can be found in Appendix B.

Monitor Connector

The Monitor Connector is a 6-pin DIN type connector. It contains two analog output signals and one analog input signal used for connection of the Interface 1000 to external devices. It is not needed for any standard Gamry Framework electrochemical tests.

The two outputs are the Cell Potential and the Cell Current monitor signals and the input is an External Signal input used to add a voltage to the Signal Generator.

Additional information on this connector, its uses, and its signals can be found in Appendix C.

The Power LED

The Power LED is located on the lower right of the Interface 1000 front panel. It normally glows a steady blue, when the Interface 1000 is turned on and has passed some simple power-on tests.

When the Interface 1000 is first turned on, the Power LED will glow steadily for a second or two, blink three times, and then go to its normal steady blue output.

When the Power LED is off, either:

- The Front Panel power switch is off.
- There is no DC +48 volt supply connected to the rear panel DC Power In connector.
- The external DC power supply has no input power or is malfunctioning.
- One part of the Power PC's power-up self-test has failed.

An Interface 1000's Power LED blinks when that instrument is selected in the Framework's Instrument Manager. This allows easy identification of a specific instrument in a MultEchem system without looking at the instrument Serial Label on the bottom of the instrument chassis.

Finally, the Power LED will continuously blink if the instrument has been subject to an over-temperature condition. In this case, the instrument will not be usable until it has been powered down, allowed to cool, and been re-powered.

Caution

The Power LED is used to indicate power status, to indicate that power-up tests have passed, to identify instruments, and to indicate latch-up due to an over-temperature event. It cannot be relied on as a true power status indicator. Always unplug the DC Power In connection if you suspect your Interface 1000 is malfunctioning.

The USB LED

The USB LED is located just below the Power LED. It is a tri-color LED, capable of glowing green, orange, or red.

The USB LED will be unlighted when:

- The Interface 1000 is not powered.
- The Interface 1000 does not have a USB cable plugged into its rear panel USB port.
- The computer end of the USB cable is not plugged into a USB port on a computer or hub.
- The USB cable is not supplying USB power to the Interface 1000.
- The computer has disabled the USB port going to the Interface 1000.

The USB LED will glow a steady green if a valid USB connection has been made and the Interface 1000's communication processor is receiving power down the USB cable.

The USB LED will flash orange whenever the Interface 1000 is receiving or transmitting valid USB messages to or from the host computer. It will not flash if there is USB traffic addressed to other devices on the USB bus, including messages aimed at a different Interface 1000.

The USB LED will indicate a solid RED in one special condition. It will be red when a firmware update is taking place. Interrupting a firmware update can cause a catastrophic failure of your system. Do not turn off the Interface 1000, do not unplug the USB cable, and do not stop the host computer operation when the USB LED is a steady red color.

Caution

Do not interrupt a firmware update while it is in progress. An incomplete update can render an Interface 1000 inoperable until it is returned to Gamry for reprogramming.

Cell LED

The Cell LED is located to the left of the Front Panel Cell connector.

The Cell LED glows yellow whenever the Interface 1000 is actively applying voltage or current to the electrochemical cell attached to the Cell Cable. You should avoid touching the cell cable leads whenever the Cell LED is lighted, because the quality of the data being collected in your experiment may be compromised.

Note

The Cell LED does not indicate a dangerous condition when it is lighted. The voltages output by the Interface 1000 are generally considered to be safe. Still, you should avoid touching the cell leads when the cell is on.

If you need to make changes to your cell leads, you normally do so between experiments, when the Cell LED is off and the potentiostat is inactive.

In a typical experimental sequence, the Cell LED will be off between experiments and during any open circuit potential measurements. It will glow yellow whenever the cell is polarized.

Overload LED

The Overload LED is located just below the Cell LED.

The Overload LED is normally unlighted. When it glows red, this indicates that some circuit in the Interface 1000 has exceeded its normal operating limit. Conditions that generate Overloads include:

- The absolute value of the differential electrometer output voltage (the difference in voltage between the Working and Reference leads) exceeds 10 volts. This condition is known as an E Overload.
- The control amplifier has lost control of the cell. The absolute value of the cell current may be trying to exceed ± 1 amp, or the absolute value of the counter electrode voltage may be trying to exceed ± 22 volts. Either condition will be called a Control Overload.
- The absolute value of the cell current has exceeded full scale on the current range presently in use. This condition is known as an I Overload.

Transient (temporary) overloads during an experiment in which the cell voltage or current is being stepped or swept are often normal. In most cases, they do not indicate a system or instrument malfunction.

Consider the case of an infinitely fast voltage step into a perfect capacitor. In theory, charging the capacitor requires an infinite current. The current spike seen at each step in a stepped voltage waveform can easily light the Overload LED. The current spike will normally decay to near zero before the actual current and voltage readings are taken.

Overload indications when the cell is being connected or disconnected are common and usually do not indicate a problem. Overloads can also be seen when one of the cell leads is disconnected from the other cell leads, even though the cell is off. Again, this does not indicate a problem.

A steadily glowing Overload LED during an experiment most likely indicates a problem is occurring. Possible causes include:

- One of the cell leads is disconnected (this is the most common cause),
- a gas bubble in the cell is blocking one of the electrodes,
- the potentiostat could be oscillating (see Chapter 7).

Note

As described above, a glowing red Overload LED does not necessarily indicate a system malfunction. The Overload LED can light when one or more cell leads are disconnected, without indicating a problem with the system. The Overload LED can often light momentarily during a swept or stepped experiment. The only Overload LED indication that definitely points towards a problem is a continuously glowing Overload LED during an experiment.

Personalization Label Area

The right side of the Interface 1000 front panel has a clear area in its plastic overlay. A paper label behind this area allows for a custom appearance. This is especially important when the instrument is in a multiple potentiostat system.

By default, the label in this area shows the instrument's Serial Number written in white text on a blue background. Interface 1000 users can chose a different label. A sheet of alternate labels is provided with each instrument and a user editable Excel file can be found on the Gamry website.

Full instructions describing the process of changing a label can be found near the end of the Installation chapter (Chapter 3).

Rear Panel

The rear panel contains several connectors. Figure 3 - 2 shows a picture of the Interface 1000 rear panel.

Power In Jack

The Power In jack is a 4-pin Power DIN connector. The Interface 1000 derives all its power from +48 volts DC input through the Power In jack. The input current is less than 1.5 amps.

We recommend that you always use the external power supply supplied with your Interface 1000 to supply DC power to the instrument. This supply is rated for operation from 100 to 240 volts AC, at frequencies from 47 to 63 Hz. It should therefore be useable worldwide. While an Interface 1000 may work with other power sources, we cannot guarantee it will work to its full specifications.

If you have to use the Interface 1000 with a different supply, make sure that the supply is regulated, has an output between 46 and 50 volts, and supplies 1.5 amps of load current.

Caution
Power input voltages less than 40 volts or greater than 52 volts can damage the Interface 1000's power supply.

Chassis Ground

The rear panel Chassis Ground banana jack is intended for one use only. When the Interface 1000 is used with cells isolated from earth ground, connecting the chassis ground to earth ground may lower the noise measured in the system. Note that the chassis of the Interface 1000 is connected to Floating Ground. Safety information concerning this is in Chapter 1.

A banana plug is the only way you can connect to the Chassis Ground jack. A wire is then used to connect the banana plug to earth ground.

A black banana-plug to banana-plug lead has been provided with your Interface 1000. You may find it useful when making this earth ground connection.

USB Port

The USB port on the rear panel of the Interface 1000 is a Type B connector as defined in Revision 1.1 and 2.0 of the USB Specification. You use a standard, shielded, Type A/B cable to connect this port to a computer's USB port or a USB hub (preferably an externally powered hub). The two ends of a Type A/B cable are different. The more-rectangular end plugs into the computer and the more-square end plugs into the Interface 1000.

A suitable USB cable was included with your Interface 1000 shipment. If this cable is lost, you can replace it with a cable from your local computer retailer.

The Interface 1000 is a High Speed USB 2.0 peripheral, capable of data transfer at 480 Mbits/second. If it is plugged into a computer port incapable of High Speed operation it will downgrade to USB 1.1 full speed operation (12 Mbits/second) causing slower data transfer.

The Interface 1000 USB port is compatible with Revision 1.1 and 2.0 of the USB specification. It supports the Windows Plug-n-Play mechanism, including dynamic connect/reconnect.

The front panel USB LED should be green whenever a valid computer to Interface 1000 connection has been made and both the computer and Interface 1000 are fully powered.

User I/O Connector

The User I/O connector contains digital signals used to interface external devices to the Interface 1000. All of its signals are referenced to earth ground so their connection does not compromise the Interface 1000 ground isolation. Interface 1000s with instruments that start with 06001 or higher also include an auxiliary voltage output that can provide voltages from 0 to 5 V.

A full description of this connector can be found in Appendix C of this manual. This appendix includes details such as connector pin-out, output and input voltage levels and full signal descriptions.

The following list is a short description of the signals in the User I/O Connector and their uses:

- A 12-bit D/A converter used to set “continuously variable” settings such as electrode rotation rate on a rotating disc electrode.
- Four digital outputs can be used to turn on external devices under control of an Explain experimental control script.
- Some of Gamry applications assign three of the digital outputs to control stirring, flow of de-aeration gas, and formation of mercury drops on a mercury drop electrode.
- Four digital inputs that can be read in an Explain experimental control script.
- This connector includes a 5 volt power supply that can provide up to 50 mA of current for external circuitry.

Caution

Floating operation of Interface 1000 can be compromised by improper cabling to the User I/O Connector. We do not recommend use of standard 15-pin shielded cables with this connector. Custom cables with the shield connected to pin 6 of the D-connector are preferred.

Sync Port

The Sync Port is used when several Interface 1000 instruments need to be operated with a common clock and simultaneous data acquisition. It is an 8-pin mini-DIN connector.

Simultaneous operation is only required when several instruments are connected to a single electrochemical cell. Examples include rotating ring-disk voltammetry, series flow cells, localized EIS systems, and electrochemical microscopy. In these examples, data acquisition starts and stops on all the system's potentiostats simultaneously and any excitation signals are closely coupled to data acquisition.

Simultaneous operation is generally not required when instruments are connected to different electrochemical cells. A good example is parallel testing of batteries. You might want to start a number of tests simultaneously, but the tests need not remain synchronous and they can end independently.

A full description of the Sync Port can be found in Appendix C of this manual.

Chapter 6 -- Instrument Circuitry

Interface 1000 Schematic/Block Diagrams

If you are not familiar with electronic schematics or potentiostats, you probably want to skip this chapter. This information is for expert use only and is not required for routine use of the Interface 1000.

The following figures are partly schematic diagrams and partly block diagrams. They are intended to show the basic principles of the Interface 1000 without the confusion of the full circuitry details. The complexity of the Interface 1000 can be quite daunting – the Interface 1000 circuit boards contain more than 2000 components connected by almost 5000 circuit nets.

The schematic/block diagram figures show:

- the Interface 1000 in its potentiostatic control mode,
- the circuits for signal generation,
- the circuits for signal conditioning and A/D conversion,
- the processors in the Interface 1000,
- DC-DC power conversion.

Warning

If your instrument should malfunction, Gamry Instruments does not recommend user repair. The information provided here is not sufficient for troubleshooting problems in an Interface 1000. Contact Gamry Instruments at support@gamry.com or your local Gamry representative if you have problems.

Figure 6-1
Interface 1000 Potentiostat Board in Potentiostat Mode

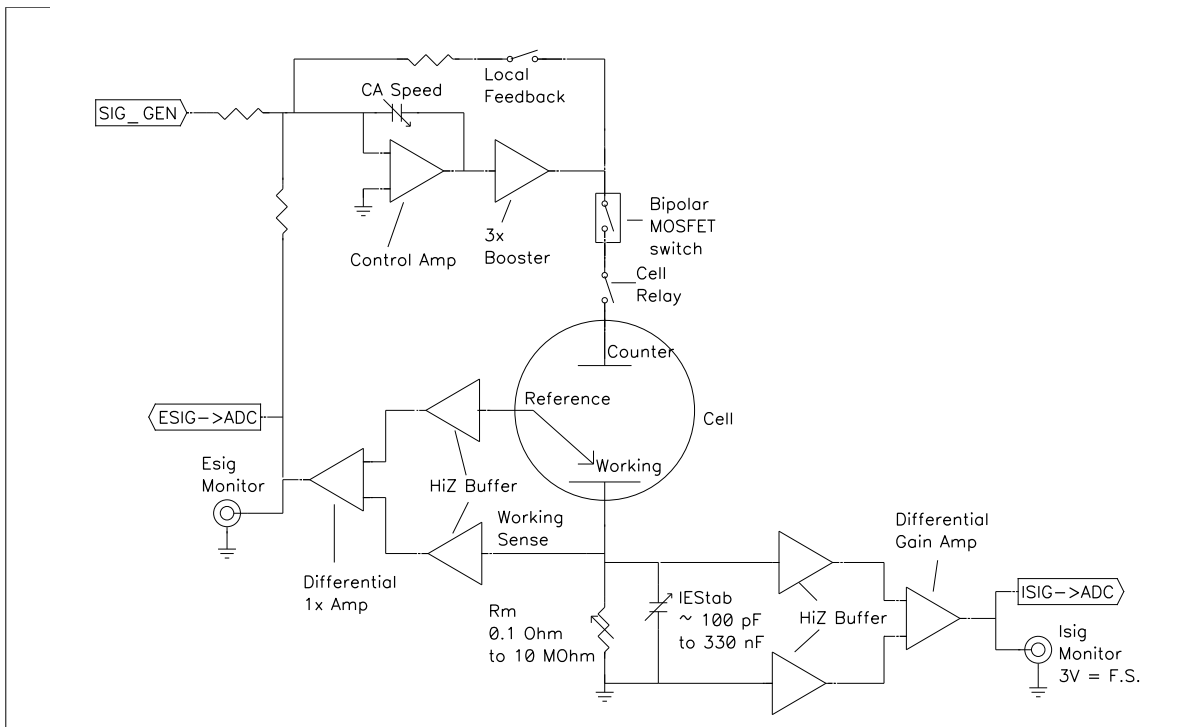

Notes for Figure 6-1

- Only Potentiostat Mode circuitry is shown in this figure. In this mode the voltage difference between the Reference and Working Sense leads (called Esig) is fed back into the control amplifier.
- In Galvanostat Mode, the feedback is from Isig. In ZRA mode, the feedback is from a differential amplifier measuring the difference between the Counter Sense and Working Sense leads of the cell cable. The counter sense circuitry is not shown. It is conceptually similar to the voltage sensing circuit that generates Esig.
- Switches are either computer controlled reed relays or MOS switches as appropriate
 - All components shown as being variable (resistance Rm, capacitor IESstab and capacitor CASpeed) are actually several fixed value components switched into the circuit. They are not continuously variable as implied in the figure.
 - The monitor connections for Isig and Esig are filtered using an RLC circuit.
 - All the resistors summing voltages into the Control Amplifier input do not have values shown – their values depend on scaling factors too complex to discuss in this simplified diagram.
 - Calibration components are not shown.
 - Overload protection and overload detection are not shown. Good engineering practice demands that any possible misconnection of the cell leads will not damage the instrument. This practice has been followed in the Interface 1000 design.

Figure 6-2
Interface 1000 Signal Generation Circuitry

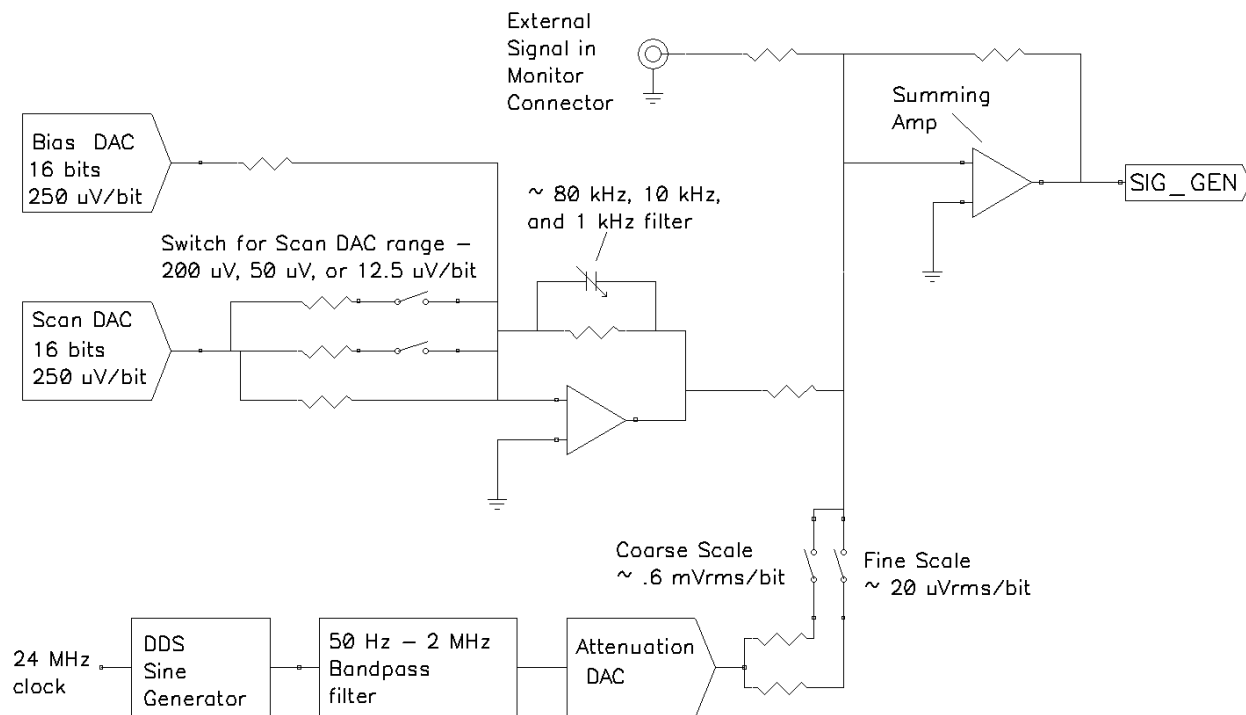

Notes on Figure 6-2:

- All the resistors summing voltages into the Summing Amplifier input do not have values shown because their values depend on scaling factors too complex for this simplified diagram.
- Calibration components are not shown.
- High frequency sine wave generation is done using a DDS (direct digital synthesis) IC. The DDS's output is filtered with both a high pass and low pass filter. The low pass filter removes the steps in the DDS output. The high pass filter provides AC coupling to prevent drift in the DDS's offset getting into the applied signal. In practice, Gamry EIS software uses the DDS to apply sine waves with frequencies between 100 Hz to 1 MHz. It uses the Scan DAC to generate sine signals at frequencies below 100 Hz.

A two stage attenuator scales the DDS. On the coarse scale, the maximum output signal is $2.33 V_{rms}$ ($3.3 V_{peak}$) and the resolution is approximately $0.6 mV_{rms}/bit$. On the fine scale, the maximum is approximately $77 mV_{rms}$ and the resolution is approximately $20 \mu V_{rms}/bit$. AC signal attenuation is handled automatically by Gamry software.

- The Scan DAC and Bias DAC signals are filtered before they are applied to the cell. The filter bandwidths are as shown.

Figure 6-3
One A/D Signal Chain in the Interface 1000

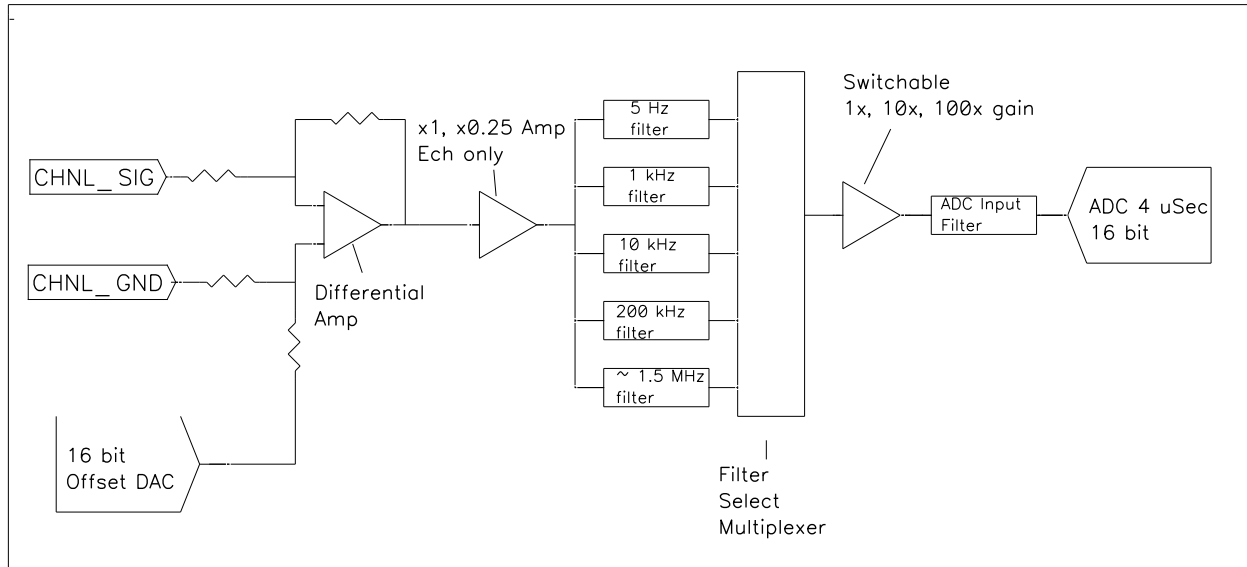

Notes for Figure 6-3:

- This diagram shows one of two identical ADC channels. One channel is dedicated to measurement of the potentiostat's current signal and the other is used to measure the voltage signal.
- Both A/D converters are triggered simultaneously to start a conversion. This trigger and the pulse updating the Scan DAC voltage are under the control of a hardware state-machine. This insures that all waveform and data acquisition timing is tightly controlled and reproducible point-to-point.

By default, the data acquisition is synchronized with the system's 600 kHz power supply switching frequency reducing noise due to the power supply. Data acquisition times that are a multiple of 1.666 μ Sec will maintain this synchronization.

- All analog signals are received differentially as shown here.
- The 5 Hz, 1 kHz, 10 kHz, 200 kHz and 1.4 MHz filters are 2-pole Butterworth filters.
- The voltage measurement channel includes a programmable 1x - 0.25x gain circuit. In the 0.25 gain position, voltages as high as 12 volts can be measured.

Figure 6-4
Microprocessors in the Interface 1000

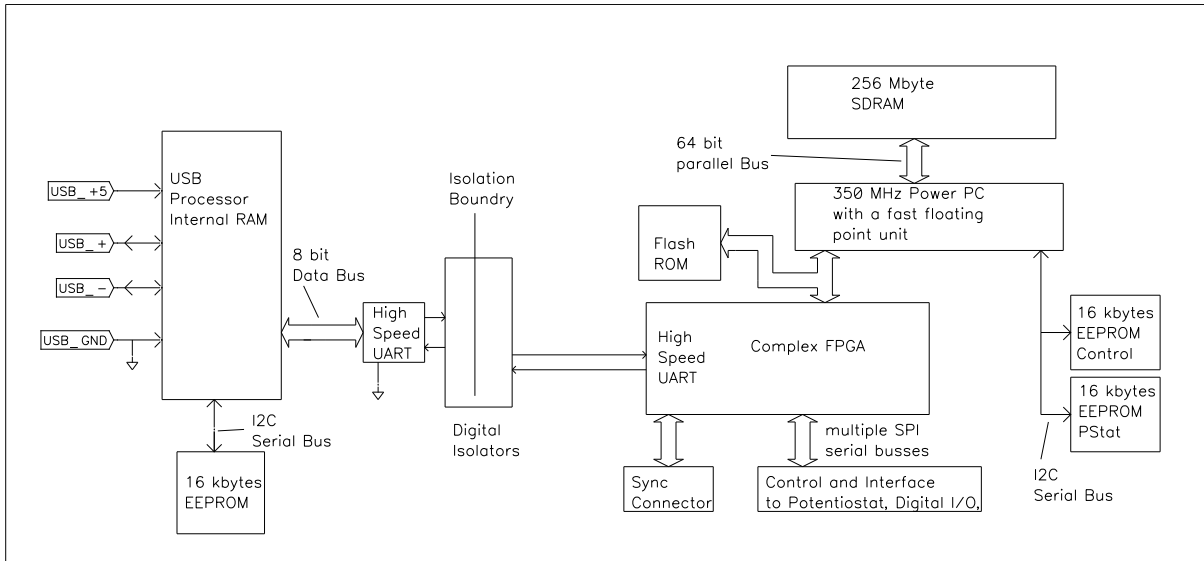

Notes for Figure 6-4:

- Note the lack of a ground connection between the USB bus and the Interface 1000 circuitry.
- The USB Processor firmware is loaded into its RAM on power-up.
- The Power PC firmware is also transferred from ROM into RAM on power-up. Time critical sections of the Power PC code are kept in the processor's fast cache memory.
- The term UART refers to a Universal Asynchronous Receiver Transmitter. It converts parallel data to a serial bit stream. The UARTs send data at 6 Mbits/second.
- The Interface 1000 has local non-volatile data storage. This is used to save calibration data and board revision information. Interface 1000 calibration data is stored in the instrument, not in a data file. When an Interface 1000 is moved from one computer to another, its calibration remains valid.
- The FPGA code can be updated in the field over the USB connection.
- The Windows device manager can be used for field update of all three programmable parts: the USB Processor, the Power PC, and the FPGA. Binary code for the updates can be obtained from the Gamry Website. If you need assistance with field updates, contact Gamry technical support at techsupport@gamry.com or contact your local Gamry representative.

**Figure 6-5
Power Conversion**

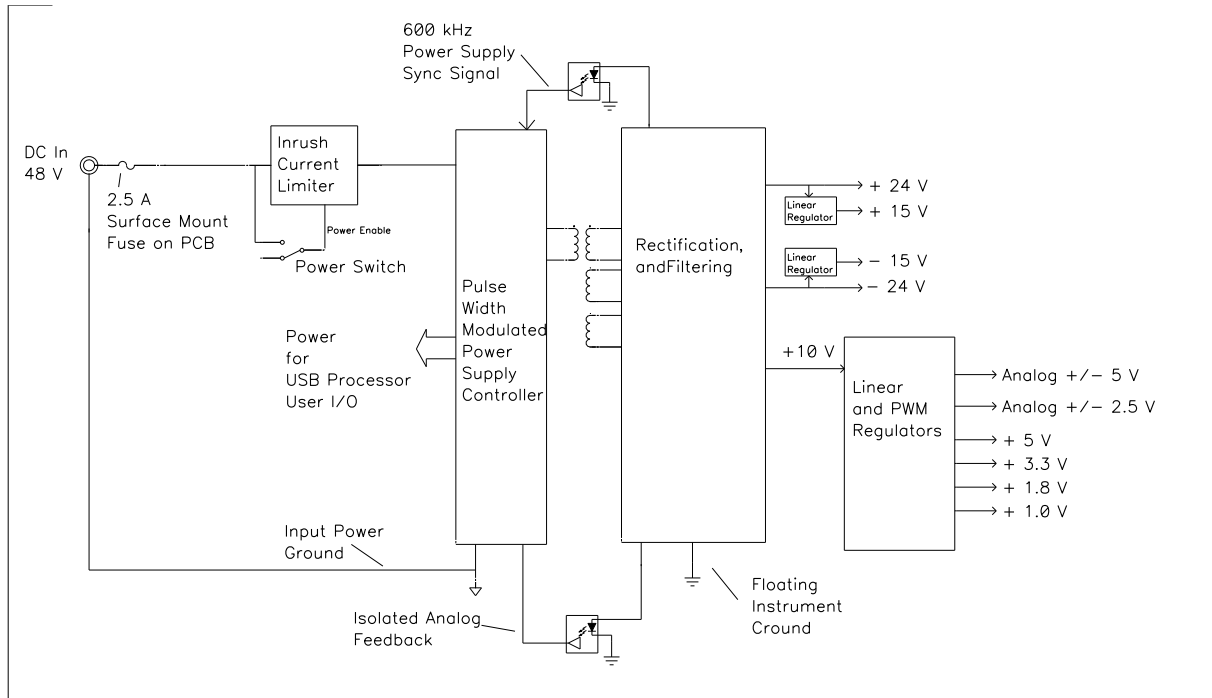

Notes for Figure 6-5:

- Note the ground isolation between the input power and the Interface 1000 circuitry. The Interface 1000 chassis is connected to the Floating Instrument Ground. Transformers and digital isolators are the only components connected between the grounds.
- The 600 kHz power supply sync signal is derived from the same clock used to control data acquisition. Data points taken at an integer multiple of 1.6666 μ Sec/point will be synchronized with the power supply, minimizing the effect of power supply noise on the data.
- The DC-DC Converter powers both the floating circuitry and some earth-side circuitry including the USB processor and User I/O.
- Additional circuitry protects the Interface 1000 against ESD and electrical surges.
- Like most complex electronic apparatus, the Interface 1000 uses a variety of power supply voltages.
- The incoming DC voltage must be between 46 and 50 volts. With inputs below 46 volts, the PWM may be unable to regulate the supply. Above 50 volts, the PWM may not start-up.

Warning

Do not use a DC power source other than the AC adapter model provided with your Interface 1000 or a Gamry supplied alternative. Other power sources may void the performance and/or safety characteristics of the Interface 1000

Caution

Power input voltages less than 40 volts or greater than 52 volts can damage the Interface 1000's power supply

Chapter 7 -- Stability in Potentiostat Mode

Capacitive Cells and Stability

All potentiostats can become unstable when connected to capacitive cells. The capacitive cell adds phase shift to the potentiostat's feedback signal (which is already phase shifted). The additional phase shift can convert the potentiostat's power amplifier into a power oscillator.

To make matters worse, almost all electrochemical cells are capacitive because an electrical double layer forms next to a conductor immersed in a solution.

Potentiostat oscillation is an AC phenomenon. However, it can affect both AC and DC measurements. Oscillation often causes excessive noise or sharp DC shifts in the system's graphical output. The Interface 1000 Potentiostat can be stable on less sensitive current ranges and unstable on more sensitive current ranges. Whenever you see sharp breaks in the current recorded on the system, you should suspect oscillation.

The Interface 1000 has been tested for stability with cell capacitors between 10 pF and 3000 F. In all but its fastest control amp speed setting, it is stable on any capacitor in this range -- as long as the impedance in the reference electrode lead does not exceed 20 k Ω . With reference electrode impedances greater than 20 k Ω , the Interface 1000 may oscillate. The RC filter formed by the reference electrode impedance and the reference terminal's input capacitance filters out the high frequency feedback needed for potentiostat stability.

Longer cell cables make the problem worse by increasing the reference terminal's effective input capacitance.

Even when the system is stable (not oscillating), it may exhibit ringing whenever there is a voltage step applied to the cell. The Interface 1000's D/A converters routinely apply steps, even when making a pseudo-linear ramp. While this ringing is not a problem with slow DC measurements, it can interfere with faster measurements. The steps taken to eliminate potentiostat oscillation also help to minimize ringing.

Improving Potentiostat Stability

There are a number of things that you can do to improve an unstable or marginally stable Interface 1000 potentiostat/cell system. This list is not in any particular order. Any or all of these steps may help.

- Slow down the potentiostat. The Interface 1000 has five control amplifier speed settings, which can be selected in software. Slower settings are generally more stable.
- Increase the Interface 1000 I/E stability setting. The Interface 1000 includes three capacitors that can be paralleled with its I/E converter resistors. These capacitors are connected to relays that are under software control. Contact your local Gamry Instruments representative for more information concerning changes in these settings.
- Lower the reference electrode impedance. Make sure that you don't have a clogged reference electrode junction. Avoid asbestos fiber reference electrodes and double-junction electrodes. Avoid small diameter Luggin capillaries. If you do have a Luggin capillary, make sure that the capillary's contents are as conductive as possible.
- Add a capacitively coupled low impedance reference element in parallel with your existing reference electrode. The classic fast combination reference electrode is a platinum wire and a junction isolated SCE. See Figure 7-1. The capacitor insures that DC potential comes from the SCE and AC potential from the platinum wire. The capacitor value is generally determined by trial and error.

Figure 7-1
Fast Combination Reference Electrode

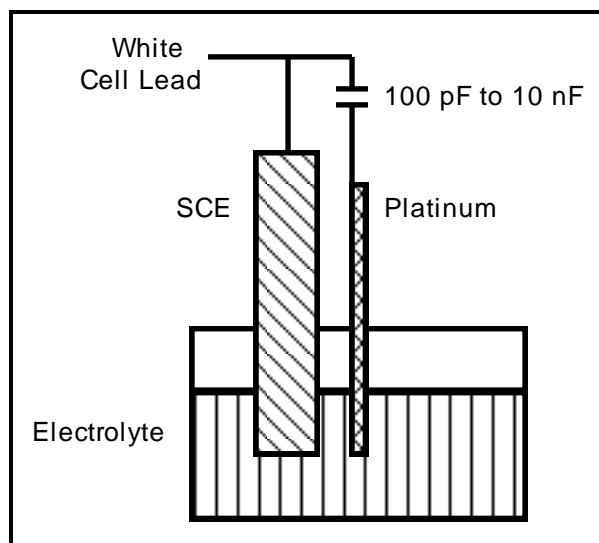

- Provide a high frequency shunt around the cell. A small capacitor between the red and white cell leads allows high frequency feedback to bypass the cell. See Figure 7-2. The capacitor value is generally determined by trial and error. One nF (1000 pF) is a good starting point.

In a sense, this is another form of an AC coupled low impedance reference electrode. The counter electrode is the low impedance electrode, eliminating the need for an additional electrode in the solution.

Figure 7-2
High Frequency Shunt

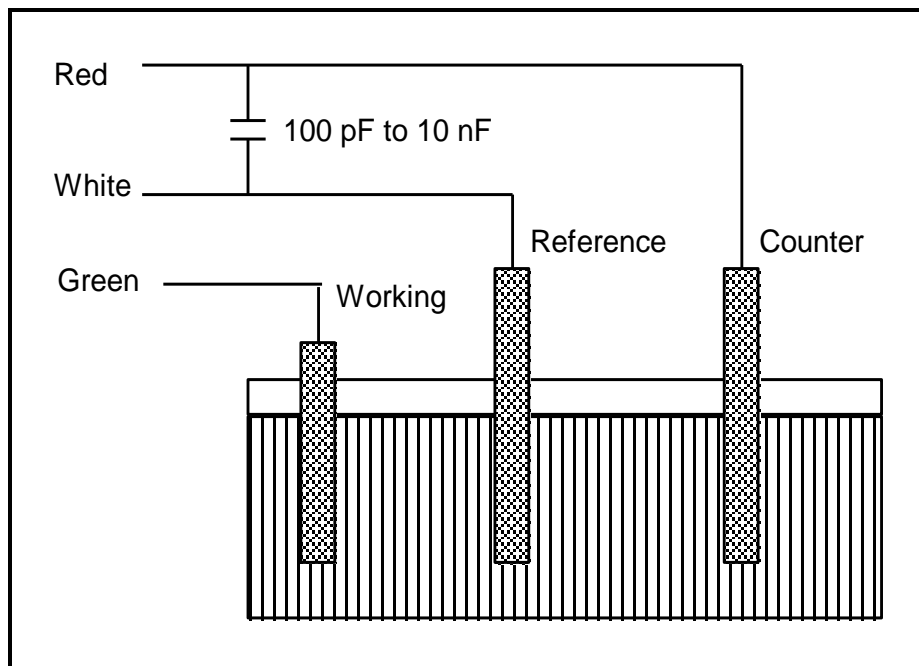

- Add resistance to the counter electrode lead. See Figure 7-3. This change lowers the effective bandwidth of the control amplifier. As a rule of thumb, the resistor should be selected to give one volt of drop at the highest current expected in the test being run. For example, if you expect your highest current to be around 1 mA, you can add a 1 k Ω resistor.

This resistor has no effect on the DC accuracy of the potentiostat. It can create problems in high-speed experiments such as fast CV scans or EIS, which need high bandwidth.

Figure 7-3
Resistor Added for Stability

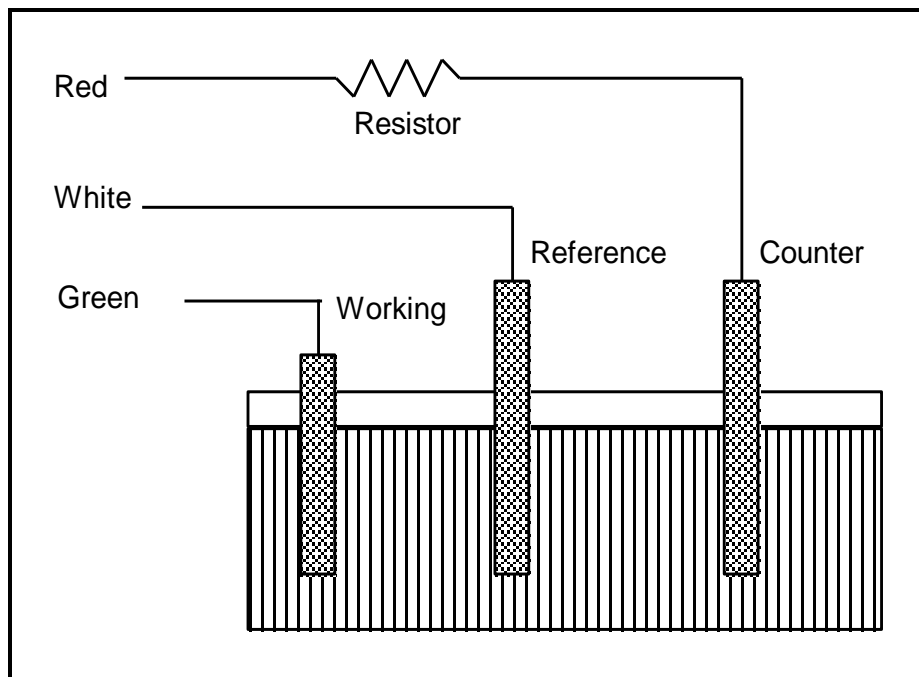

Chapter 8 -- Measurement of Small Signals

Overview

The Interface 1000 is a very sensitive scientific instrument. It can theoretically resolve current changes as small as 333 femtoamp (333×10^{-15} amps). To place this current in perspective, 333 fA represents the flow of about 2000000 electrons per second!

The small currents measured by the Interface 1000 place demands on the instrument, the cell, the cables and the experimenter. Many of the techniques used in higher current electrochemistry must be modified when used to measure pA currents. In many cases, the basic physics of the measurement must be considered.

This chapter will discuss the limiting factors controlling low current measurements. It will include hints on cell and system design. The emphasis will be on EIS (Electrochemical Impedance Spectroscopy), a highly demanding application for the Interface 1000.

Measurement System Model and Physical Limitations

To get a feel for the physical limits implied by very sensitive current measurements, consider the equivalent circuit shown in Figure 8-1. We are attempting to measure the cell impedance given by Z_{cell} .

This model is valid for analysis purposes even though the real Interface 1000 circuit topology differs significantly.

In Figure 8-1:

E_s	Is an ideal signal source
Z_{cell}	Is the unknown cell impedance
I_{cell}	Is the "real" cell current
R_m	Is the current measurement circuit's current measurement resistance
R_{shunt}	Is an unwanted resistance across the cell
C_{shunt}	Is an unwanted capacitance across the cell
C_{in}	Is the current measurement circuit's stray input capacitance
R_{in}	Is the current measurement circuit's stray input resistance
I_{in}	Is the measurement circuit's input current

In the ideal current measurement circuit R_{in} is infinite while C_{in} and I_{in} are zero. All of the cell current, I_{cell} , flows through R_m .

With an ideal cell and voltage source, R_{shunt} is infinite and C_{shunt} is zero. All the current flowing into the current measurement circuit is due to Z_{cell} .

The voltage developed across R_m is measured by the meter as V_m . Given the idealities discussed above, one can use Kirchoff's and Ohms law to calculate Z_{cell} :

$$Z_{\text{cell}} = E_s * R_m / V_m$$

Figure 8-1
Equivalent Measurement Circuit

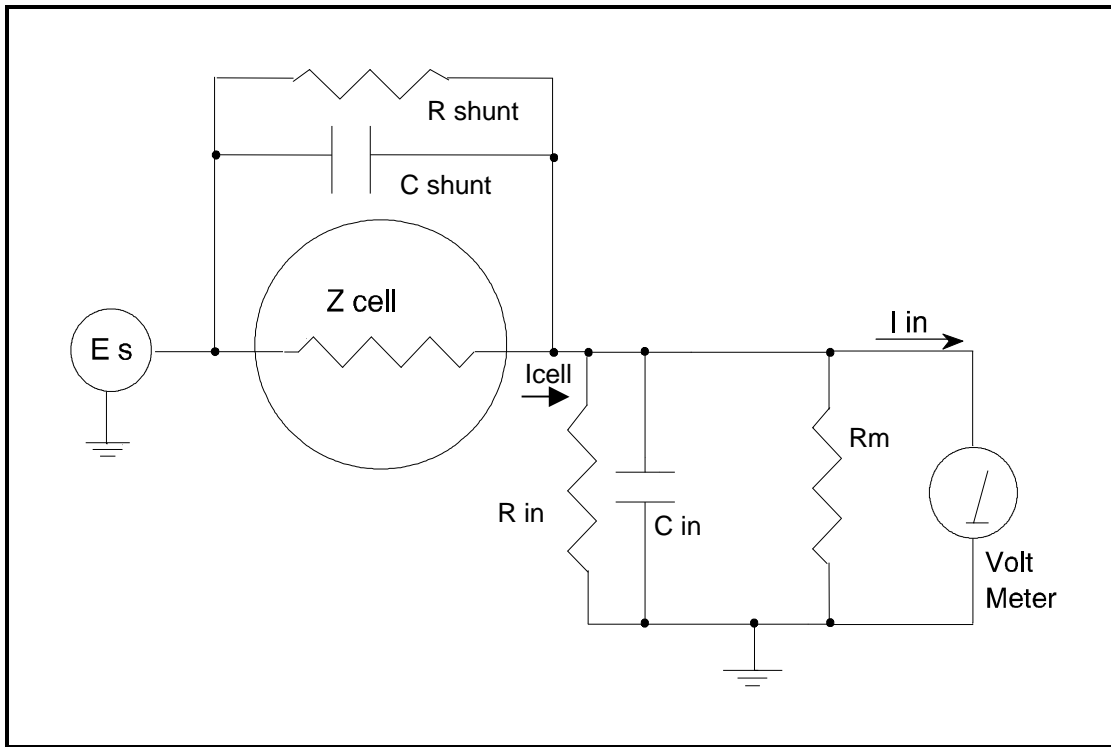

Unfortunately, technology limits high impedance measurements because:

- Current measurement circuits always have non-zero input capacitance, i.e. $C_{in} > 0$.
- Infinite R_{in} cannot be achieved with real circuits and materials.
- Amplifiers used in the meter have input currents, i.e. $I_{in} > 0$.
- The cell and the potentiostat create both a non-zero C_{shunt} and a finite R_{shunt} .

Additionally, basic physics limits high impedance measurements via Johnson noise, which is the inherent noise in a resistance.

Johnson Noise in Z_{cell}

Johnson noise across a resistor represents a fundamental physical limitation. Resistors, regardless of composition, demonstrate a minimum noise for both current and voltage, per the following equations:

$$E = (4 k T R \delta F)^{1/2}$$

$$I = (4 k T \delta F / R)^{1/2}$$

Where;

k = Boltzman's constant $1.38 \times 10^{-23} \text{ J/}^\circ\text{K}$

T = temperature in $^\circ\text{K}$

δF = noise bandwidth in Hz

R = resistance in ohms.

For purposes of approximation, the Noise bandwidth, δF , is equal to the measurement frequency. Assume a 10^{11} ohm resistor as Z_{cell} . At $300 \text{ }^\circ\text{K}$ and a measurement frequency of 1 Hz this gives a voltage noise of

41 μV rms. The peak-to-peak noise is about 5 times the rms noise. Under these conditions, you can make a voltage measurement of ± 10 mV across Z_{cell} with an error of about $\pm 0.4\%$. Fortunately, an AC measurement can reduce the bandwidth by integrating the measured value at the expense of additional measurement time. With a noise bandwidth of 1 mHz, the voltage noise falls to about 1.3 μV rms.

Current noise on the same resistor under the same conditions is 0.41 fA. To place this number in perspective, a ± 10 mV signal across this same resistor will generate a current of ± 100 fA, or again an error of up to $\pm 0.4\%$. Again, reducing the bandwidth helps. At a noise bandwidth of 1 mHz, the current noise falls to 0.013 fA.

With E_s at 10 mV, an EIS system that measures 10^{11} ohms at 1 Hz is about $2 \frac{1}{2}$ decades away from the Johnson noise limits. At 10 Hz, the system is close enough to the Johnson noise limits to make accurate measurements impossible. Between these limits, readings get progressively less accurate as the frequency increases.

In practice, EIS measurements usually cannot be made at high enough frequencies that Johnson noise is the dominant noise source. If Johnson noise is a problem, averaging reduces the noise bandwidth, thereby reducing the noise at a cost of lengthening the experiment.

Finite Input Capacitance

C_{in} in Figure 8-1 represents unavoidable capacitances that always arise in real circuits. C_{in} shunts R_m , draining off higher frequency signals and limiting the bandwidth that can be achieved for a given value of R_m . This calculation shows at which frequencies the effect becomes significant. The frequency limit of a current measurement (defined by the frequency where the phase error hits 45°) can be calculated from:

$$f_{\text{RC}} = 1 / (2 \pi f R_m C_{\text{in}})$$

Decreasing R_m increases this frequency. However, large R_m values are desirable to minimize the effects of voltage drift and voltage noise in the I/E converter's amplifiers.

A reasonable value for C_{in} in a practical, computer controllable, low current measurement circuit is 20 pF. For a 6 nA full scale current range, a practical estimate for R_m is 10^7 ohms.

$$f_{\text{RC}} = 1 / 6.28 (1 \times 10^7)(2 \times 10^{-12}) \approx 8000 \text{ Hz}$$

In general, one should stay two decades below f_{RC} to keep phase shift below one degree. The uncorrected upper frequency limit on a 6 nA range is therefore around 80 Hz.

One can measure higher frequencies using the higher current ranges (i.e. lower impedance ranges) but this would reduce the total available signal below the resolution limits of the "voltmeter". This then forms one basis of statement that high frequency and high impedance measurements are mutually exclusive.

Software correction of the measured response can also be used to improve the useable bandwidth, but not by more than an order of magnitude in frequency.

Leakage Currents and Input Impedance

In Figure 8-1, both R_{in} and I_{in} affect the accuracy of current measurements. The magnitude error due to R_{in} is calculated by:

$$\text{Error} = 1 - R_{\text{in}} / (R_m + R_{\text{in}})$$

For an R_m of 10^7 ohms, an error $< 1\%$ demands that R_{in} must be greater than 10^9 ohms. PC board leakage, relay leakage, and measurement device characteristics lower R_{in} below the desired value of infinity.

A similar problem is the finite input leakage current I_{in} into the voltage measuring circuit. It can be leakage directly into the input of the voltage meter, or leakage from a voltage source (such as a power supply) through an insulation resistance into the input. If an insulator connected to the input has a 10^{12} ohm

resistance between +15 volts and the input, the leakage current is 15 pA. Fortunately, most sources of leakage current are DC and can be tuned out in impedance measurements. As a rule of thumb, the DC leakage should not exceed the measured AC signal by more than a factor of 10.

The Interface 1000 uses an input amplifier with an input current of around 1 pA. Other circuit components may also contribute leakage currents. You therefore cannot make absolute current measurements of very low pA currents with the Interface 1000. In practice, the input current is approximately constant, so current differences or AC current levels of less than one pA can often be measured.

Voltage Noise and DC Measurements

Often the current signal measured by a potentiostat shows noise that is not the fault of the current measurement circuits. This is especially true when you are making DC measurements. The cause of the current noise is noise in the voltage applied to the cell.

Assume that you have a working electrode with a capacitance of 40 μF . This could represent a 1 cm^2 polished bare metal immersed in an electrolyte solution. You can roughly estimate the capacitance of the electrical double layer formed by a metal/electrolyte interface as 20 $\mu\text{F}/\text{cm}^2$. The area is the microscopic area of the surface, which is larger than the geometric area, because even a polished surface is rough. The impedance of this 40 μF electrode, assuming ideal capacitive behavior, is given by:

$$Z = 1/j\omega C$$

At sixty Hertz, the impedance magnitude is about 66 Ω .

Apply an ideal DC potential across this ideal capacitor and you get no DC current.

Unfortunately, all potentiostats have noise in the applied voltage. This noise comes from the instrument itself and from external sources. In many cases, the predominant noise frequency is the AC power line frequency.

Assume a realistic noise voltage, V_n , of 10 μV (this is lower than the noise level of most commercial potentiostats). Further, assume that this noise voltage is at the US power line frequency of 60 Hz. It will create a current across the cell capacitance:

$$I = V_n/Z \approx 10 \times 10^{-6}/66 \approx 150 \text{ nA}$$

This rather large noise current will prevent accurate DC current measurement in the low nA or pA ranges.

In an EIS measurement, you apply an AC excitation voltage that is much bigger than the typical noise voltage, so this is not a factor.

Shunt Resistance and Capacitance

Non-ideal shunt resistance and capacitance arise in both the cell and the potentiostat. Both can cause significant measurement errors.

Parallel metal surfaces form a capacitor. The capacitance rises as either metal area increases and as the separation distance between the metals decreases.

Wire and electrode placement have a large effect on shunt capacitance. If the clip leads connecting to the working and reference electrodes are close together, they can form a significant shunt capacitor. Values of 1 to 10 pF are common. This shunt capacitance cannot be distinguished from "real" capacitance in the cell. If you are measuring a paint film with a 100 pF capacitance, 5 pF of shunt capacitance is a very significant error.

Shunt resistance in the cell arises because of imperfect insulators. No material is a perfect insulator (one with infinite resistance). Even Teflon™, which is one of the best insulators known, has a bulk resistivity of about 10^{12} ohms•m. Worse yet, surface contamination often lowers the effective resistivity of good insulators. Water films can be a real problem, especially on glass.

Shunt capacitance and resistance also occur in the potentiostat itself. The Interface 1000 Potentiostat Mode specifications in Appendix A contain equivalent values for the potentiostat's R_{shunt} and C_{shunt} . These values can be measured by an impedance measurement with no cell.

In most cases, the cell's shunt resistance and capacitance errors are larger than those from the potentiostat.

Hints for System and Cell Design

The following hints may prove helpful.

Faraday Shield

A Faraday shield surrounding your cell is mandatory for very low-level measurements. It reduces both current noise picked up directly on the working electrode and voltage noise picked up by the reference electrode.

A Faraday shield is a conductive enclosure that surrounds the cell. The shield can be constructed from sheet metal, fine mesh wire screen, or even conductive paint on plastic. It must be continuous and completely surround the cell. Don't forget the areas above and below the cell. All parts of the shield must be electrically connected. You will need an opening in the shield large enough to allow a cell cable to enter the shield.

Gamry offers a Faraday shield called the Vista Shield that features a transparent window so you can see your electrochemical test running. It can be used with any potentiostat.

The Faraday shield must be electrically connected to the Interface 1000's floating ground terminal.

An additional connection of both the shield and the Interface 1000 floating ground to an earth ground may also prove helpful.

NOTE

Only connect the Interface 1000 ground to earth ground if all conductive cell components are well isolated from earth ground. A glass cell is usually well isolated. An autoclave is generally not well isolated.

Avoid External Noise Sources

Try to keep your system away from electrical noise sources. Some of the worst are:

- Fluorescent lights
- Motors
- Radio transmitters
- Computers and computer monitors

Try to avoid AC powered or computerized apparatus within your Faraday shield.

Cell Cable Length and Construction

The Interface 1000 is shipped with a 60 cm shielded cell cable. We also offer extended length cables and a special cable for low impedance cells as extra cost options.

Cell cables longer than 1 meter will result in degraded instrument performance. Increased noise and decreased stability both can occur. However, with most cells, the instrument will work acceptably with an extended cell cable, so our advice is go ahead and try it. As a rule, you should not attempt to use current interrupt IR compensation with cell cables longer than 5 meters.

We do not recommend that you use the Interface 1000 with any cables not supplied by Gamry Instruments. The Interface 1000 cable is not a simple cable like a typical computer cable. The Interface 1000 cable includes a number of individually shielded wires contained within an overall shield. We pay careful attention to issues such as shield isolation, isolation resistance, and capacitance.

If you do need a special cable, contact us with your requirements.

Lead Placement

Many experiments with the Interface 1000 involve cells with small capacitances, the value of which may be important.

In these cases, the capacitance between the Interface 1000 cell leads can result in an error. The Interface 1000 alligator clips can have 10 pF or more of mutual capacitance if they are run alongside each other.

If you wish to avoid excessive capacitance:

- Place the leads as far apart as possible. Pay special attention to physical separation between the working electrode/ working sense leads and the counter/ counter sense/ reference electrode leads.
- Have the leads approach the cell from different directions.
- Remove the alligator clips from the leads. In extreme cases you can replace the banana plugs and pin jack with smaller connectors. If you do so, be careful not to compromise the isolation between the center conductor and the shield.

The cell leads must not be moved during an experiment measuring small currents. Both microphonic and triboelectric effects can create spurious results when the cell cables are moved.

Cell Construction

If you need to measure small currents or high impedances, make sure that your cell construction does not limit your response.

A cell where the resistance between the electrodes is only 10^{10} ohms cannot be used to measure 10^{13} ohm impedances. In general, glass and Teflon are the preferred cell construction materials. Even glass may be a problem when it is wet.

You also must worry about C_{shunt} . Make the "inactive" portion of your electrodes as small as possible. Avoid placing electrodes close together or parallel with each other if you are measuring high impedances.

Reference Electrode

Keep your reference electrode impedance as low as possible. High impedance reference electrodes can cause potentiostat instability and excessive voltage noise pickup.

Try to avoid:

- Narrow bore or Vycor tipped Luggin capillaries.
- Poorly conductive solutions - especially in Luggin capillaries.
- Asbestos thread and double junction reference electrodes.

Reference electrodes often develop high impedances as they see use. Anything that can clog the isolation frit can raise the electrode impedance. Avoid using saturated KCl based references in perchlorate ion solutions

Instrument Settings

There are several things to remember in setting up a very sensitive experiment.

- In EIS, use the largest practical excitation. Don't use a 10 mV excitation on a coated specimen that can handle 100 mV without damage.

- Avoid potentials where large DC currents flow. You cannot measure 1pA of AC current on top of 1 mA of DC current.

EIS Speed

In EIS, do not expect the Interface 1000 to measure 10^{10} ohm impedances at 1 kHz. Many of the factors listed above limit the performance.

As a rule of thumb, the product of Impedance, Z, times frequency, f, should be less than 10^9 Ω Hz for good EIS measurements with an Interface 1000.

$$Z \cdot f < 10^9 \Omega\text{Hz}$$

Ancillary Apparatus

Do not use the Interface 1000 with ancillary apparatus connected directly to any of the cell leads. Ammeters and voltmeters, regardless of their specifications, almost always create problems when connected to the Interface 1000 cell leads.

Floating Operation

The Interface 1000 is capable of operation with cells where one of the electrodes or a cell surface is at earth ground. Examples of earth grounded cells include: autoclaves, stress apparatus, pipelines, storage tanks and battleships. The Interface 1000 internal ground is allowed to float with respect to earth ground when it works with these cells, hence the name floating operation.

Instrument performance can be substantially degraded when the Interface 1000 is operated in a floating mode. The instrument specifications only apply on isolated cells with the Interface 1000 earth ground referenced (not floating).

Special precautions must be taken with the cell connections when the Interface 1000 must float. Make sure that all the cell connections are isolated from earth ground. In this case, you must disconnect the chassis ground terminal of the Interface 1000 from earth ground.

Finally, ancillary apparatus connected to the Interface 1000 must be isolated. External voltmeters, ammeters, FRA's etc. must be isolated. This includes devices connected to the monitor connector located on the Interface 1000 front panel.

Cables used with the User I/O Connector must be carefully constructed. We do not recommend connection to the User I/O connector using a 15 conductor shielded cable. The shield will generally be connected to the metal shell of the User I/O connector on the Interface 1000 end of the cable. The shield will often be connected to an earth ground on the other end of the cable. Connecting the grounds in this way destroys the Interface 1000's ability to float and to make measurements on earth grounded cells. In extreme cases, this connection can cause damage to the Interface 1000.

Appendix A -- Interface 1000 Specifications

All specifications are at an ambient temperature of 22°C, with the Interface 1000 powered using the external power supply shipped with the unit, a standard shielded 60 cm cell cable, and the cell enclosed in a Faraday shield. All specifications are after software calibration.

A numbered note qualifies many of the specifications. Many of these notes describe the method used to measure a specification. The notes are found at the end of this appendix.

All specifications are subject to change without notice.

Control Amplifier

Compliance Voltage	Min	± 22	volts	Note 1
Output Current	Min	±1000	mA	Note 2
Unity Gain Bandwidth	Typ	1100, 320, 39, 4, 0.4	kHz	Notes 3, 4
Slew Rate	Typ	10, 4.5, 0.6, 0.06, 0.006	V/μs	Notes 3, 4

Differential Electrometer

Max Input Voltage	Min	±12	volts	Note 5
Input Current	Max	25	pA	Note 6
Input Resistance Differential (between inputs) Common Mode (input to ground)	Typ	20 1	TΩ	Note 5
Input Capacitance Differential (between inputs) Common Mode (input to ground)	Typ	0.3 12	pf	Note 5
Bandwidth (–3 dB)	Min	15	MHz	Note 8
CMMR DC to 10 kHz 10 kHz to 1 MHz	Min	86 60		Note 9

Voltage Measurement

A/D Full Scale Ranges	Typ	±12.0, ±3.0	Volts	Notes 5, 10
Resolution	Typ	400, 100, 10, 1	μV/bit	
Zero Offset Error	Max	1	mV	Note 11
Gain Error	Max	0.3	%	Note 11
Offset Range	Typ	±3.2768, ±13.1072	Volts	Note 12
Post- Offset Gain	Typ	1x, 10x, 100x		

Current to Voltage Converter

Maximum Full Scale Range		1000	mA	Note 13
Minimum Full Scale Range		10 100 (after ×100 gain)	nA pA	Note 13
Voltage across Rm	Typ	100	mV at full scale	Note 14
Output Voltage (at Monitor and ADC in)	Typ	3.0	Volts full scale	
Input Offset Current	Max	10	pA	Note 15
Range Zero Offset	Max	0.05	% of range	Note 15
Gain Tolerance 1 A to 10 nA ranges	Max	0.3	% of reading	Note 15
Zero drift	Typ	0.03	% FS /°C	Note 16
Bandwidth	Typ	>1.5 MHz (10 μA) > 0.15 MHz (1 μA)	MHz	Note 17

Current Measurement

Resolution	Typ	0.00333...	% FS /bit	
Offset Range	Typ	± 100	% of range	
Post- Offset Gain	Typ	1x, 10x, 100x		
Accuracy	Typ	Dominated by current-to-voltage error (see above)		

Potentiostatic Mode

Applied Voltage Range	Max	± 12	volts	
Accuracy DC zero offset Gain	Max	1 0.2	mV % setting	Note 18
DC Bias	Typ	± 8	volts	
Scan DAC ranges	Typ	$\pm 6.4, \pm 1.6, \pm 0.4$	volts	
Drift	Max	< 20	$\mu\text{V}/^\circ\text{C}$	Note 19
Noise and Ripple 1 Hz to 1 kHz 1 Hz to 200 kHz	Typ	10 20	$\mu\text{V rms}$	Note 20

Galvanostatic Mode

Maximum Full Scale Current		± 1000	mA	
Minimum Full Scale Current		10	nA	
Accuracy		Dominated by current to voltage converter accuracy shown above		
Sig Gen Voltage for Full Scale Current		± 3.0	V	

Environmental

Operating Temperature Range		0 to 45	$^\circ\text{C}$	
Relative Humidity	Max	90 (non-condensing)	%	
Storage and Shipping Temperature		-25 to 75	$^\circ\text{C}$	
Maximum Shipping acceleration		30	G	

General

Power Input Voltage	Range	46 to 50	volts	
Power	Max	75	W	
Leakage Current (floating, earthed Working Electrode)		± 1 nA		Note 22
Dimensions		24 x 27 x 6	cm	Note 23
Weight	Max	2.0	kg	Note 23
Dimensions of External Power Adapter	Max	13 x 6 x 3	cm	Note 24
Weight of External Power Adapter	Max	300	grams	Note 24

NOTES:

1. Measured in galvanostatic mode with a high wattage 200 Ω load connected from counter electrode lead to the working electrode lead. The compliance voltage is measured using an external voltmeter across the 200 Ω load. Under these conditions, the output current is approximately 115 mA.
2. Measured with a precision 4-terminal 2 Ω load, in potentiostatic mode.
3. Unity gain bandwidth and slew rate are correlated. Each has five settings, with the highest slew rate occurring at the highest bandwidth, down to the lowest slew rate occurring at lowest bandwidth. Both are measured with 20 k Ω between counter and reference and 100 Ω between the reference and the working and working sense leads
4. Measured with an external function generator connected to the Ext Sig In BNC.
5. The A/D and signal processing chain in the Interface 1000 allows measurement of voltage signals as large as ± 13.107 V. The voltage on the Work Sense lead can be as high as ± 0.4 V when measuring 1A using a 60 cm cell cable. This implies a maximum voltage input on the differential electrometer of ± 13.6 V.
In practice, the operational amplifiers in the voltage signal processing circuitry cannot guarantee voltages beyond ± 12.5 V.
6. This specification is tested using a 2 G Ω resistor switched into the input and measuring the voltage difference with and without the input resistance.
7. The differential impedance is measured between the Reference and Work Sense inputs. This is the impedance you measure when you record the EIS spectrum of an infinite impedance (open lead) cell. There is also a common mode resistance and capacitance associated with the differential electrometer inputs. These values tell you how much the electrometer response is modified by a resistance in series with the source.
8. The bandwidth is for a sine-wave source with a 50 Ω output impedance driving either input. The bandwidth is well in excess of this specification, which is limited by the measurement equipment used in routine testing of the Interface 1000.
9. CMRR is common mode rejection ratio. It specifies the ability of the differential electrometer to reject signals connected to both inputs. The CMRR is measured driving both inputs with a sine-wave source with a 50 Ω output impedance, and measuring the error as a function of frequency. Resistance in either input will cause a loss of CMRR.
10. Voltage measurement is performed with a ± 3 nominal volt signal input to the ADC signal chain. The actual full scale is 3.2768 V. A $\div 4$ attenuator divides down higher voltage electrometer outputs so they fit into a ± 3 volt input, thus making a ± 12 volt nominal (13.1072 V) actual full scale range.

11. The total error in a voltage measurement is:

$$\text{Error} = \text{Zero Offset Error} + \text{Gain Error} * \text{Voltage}$$

For a 1 volt signal the theoretical error can be as high as 3 mV. This error is typically less than 0.5 mV.

12. Offsets are summed into the signal. Offset inaccuracy is approximately $\pm 0.05\%$ of the setting plus ± 0.5 mV.
13. There are 9 hardware current ranges, separated in sensitivity by decades. The ranges are 10 nA, , 100 nA, 1 μ A, ... 100 mA, 1 A full scale. The x10 and x100 gains add two virtual ranges of 1 nA and 100 pA full scale.
14. The voltage across the current measurement resistor, R_m , is as shown. On ranges below 1 mA, the working electrode voltage is similar to the voltage across R_m . At 1A and 1 MHz, the working electrode voltage can be as high as 0.4 V since the cable has both resistive and inductive impedance.
15. The total error in a current measurement is:

$$\text{Error} = \text{Input Current Offset} + \text{Range Zero Offset} * \text{FS Current} + \text{Gain Tolerance} * \text{Measured Current}$$

For small currents (pA) the first term is usually dominant.

For large currents (uA), the first term can usually be ignored.

The units for the error are amps.

16. Drift can be approximated by simple drift in the Range Zero Error. In reality all three terms in the equation above can have drift.
17. The Current to Voltage converter bandwidth is a function of the current range, the cell cable, and the IEStability setting. The bandwidth can be very low on very sensitive ranges. Longer cell cables add capacitance and slow the current measurement.
18. The total error in a voltage setting is:

$$\text{Error} = \text{DC Zero Offset} + \text{Gain} * \text{Voltage Setting}$$

For a 1 volt signal the theoretical error can be as high as 3 mV. In practice the error is generally less than 1 mV.

19. This specification is guaranteed by design. It is not tested.
20. This specification is measured by applying zero voltage across a 1 Ω resistor and measuring current noise on the 600 μ A scale. 1 μ V of voltage noise will create a current of 1 μ A. The filters in the ADC Chain for the I Signal are used to limit the bandwidths as shown in the spec. Signal averaging via Gamry DSP mode will further reduce the measured noise.
21. See Appendix D.
22. Isolation quality has both DC factors and AC factors (predominately at the 600 kHz power supply frequency). Only the DC leakage current is shown here. Consult Gamry technical support for additional information.
23. Excluding external power adapter and any cables supplied with unit.
24. Excluding removable line cord.

25.

Appendix B -- Interface 1000 Cell Connector

Chapter 4 describes the connections between a cell cable and an electrochemical cell. This appendix describes the other end of the cell cable.

Multiple pins assigned to the same signal are connected together on the Interface 1000's Potentiostat board. If you need to connect this signal outside the Interface 1000, you need a wire connected to any one of the D connector pins.

Table B-1
Cell Connector

Pin(s)	Signal Name	Use
1	Working Sense	Connected to the working electrode in most cases (see Chapter 4). This lead has a 261 Ohm resistor in the cell end of the cable. Custom cell cables are likely to require a similar resistor.
2, 14	WS Shield	The shield for the working sense input. Driven to the same potential as Pin 1. Left open at the cell end of the cell cable.
3, 4, 15, 17	Reference Shield	The shield for the reference electrode input. Driven to the same potential as Pin 16. Left open at the cell end of the cell cable.
5, 7, 10, 11, 18, 19, 22, 24	Ground	The potentiostat's floating ground. Can be used to shield the cell if very low currents need to be measured. Also used as a shield for the counter electrode cable.
6	Counter Sense	With an Interface 1000, used to sense the potential of the counter electrode. Allows accurate ZRA mode even with significant cell current through counter lead's resistance.
8	CBL_ID1	One of 4 cable ID bits. Used to identify the type of cell cable attached to the unit. Pull to a logic High through a resistor. Ground to set the bit low.
9	CBL_ID2	One of 4 cable ID bits. Used to identify the type of cell cable attached to the unit. Pull to a logic High through a resistor. Ground to set the bit low.
12, 25	Work Shield	The shield for the working electrode input. Connected to Floating Ground. Left open at the cell end of the cell cable.
13	Working Electrode	Connected to the working electrode. The cell current flows through this pin.
16	Reference Electrode	Connected to the reference electrode in most cases (see Chapter 4). This lead has a 261 Ohm resistor in the cell end of the cable. Custom cell cables are likely to require a similar resistor.
20	CBL_ID0	One of 4 cable ID bits. Used to identify the type of cell cable attached to the unit. Pull to a logic High through a resistor. Ground to set the bit low.
21	CBL_ID3	One of 4 cable ID bits. Used to identify the type of cell cable attached to the unit. Pull to a logic High through a resistor. Ground to set the bit low.
23	Counter Electrode	Connected to the cell's counter electrode. The cell current flows through this connection.

Caution

Designing cell cabling for a 1 MHz potentiostat is not a trivial task. Gamry Instruments does not recommend user designed cables (except as a last resort). In many cases we can build a custom cable to meet your specific needs. We'll also be happy to discuss your cabling requirements and give you assistance if you must design and build your own cell cable.

Appendix C -- I/O Connectors

The Interface 1000 includes several I/O connectors other than the Cell Connector described in Appendix B. The details of these connectors are described here.

User I/O Connector

This connector contains a number of signals, used to interface the Interface 1000 to external apparatus. It is the miniature 15 pin female D shaped connector on the rear panel of the Interface 1000.

Be careful, the ground pin (pin 6) on this connector is earth ground and the D-connector shell is the Interface 1000 Floating Ground. Improper User I/O connections can damage an Interface 1000 that is connected to a high energy cell containing earth grounded terminals.

Caution

Floating operation of Interface 1000 can be compromised by improper cabling to the User I/O Connector. We do not recommend use of standard 15-pin shielded cables with this connector. Custom cables with the shield connected to pin 6 of the D-connector are preferred.

The pin out of this connector is shown in Table C-1.

Table C-1
User I/O Connector

Pin	Name	Use
1	Analog Output High	The auxiliary output signal (DAC output)
2	Analog Output Low	The auxiliary output ground connection (ground)
6	Ground	Digital ground
7	Digital Out 0	A CMOS compatible digital output - connecting device input current must be below 10 μ A
8	Digital Out 1	A CMOS compatible digital output - connecting device input current must be below 10 μ A
9	Digital Out 2	A CMOS compatible digital output - connecting device input current must be below 10 μ A
10	Digital Out 3	A CMOS compatible digital output - connecting device input current must be below 10 μ A
11	Digital In 0	A CMOS compatible digital input- 2.2 k Ω input impedance
12	Digital In 1	A CMOS compatible digital input- 2.2 k Ω input impedance
13	Digital In 2	A CMOS compatible digital input- 2.2 k Ω input impedance
14	Digital In 3	A CMOS compatible digital input- 2.2 k Ω input impedance
15	+5 Volts	Power- 50 mA maximum current

Sync Port

The Sync Port is used to interconnect Interface 1000s that must be operated synchronously – with a single clock and with simultaneous data acquisition. The sync connector is a 7-pin mini-DIN connector located on the rear panel of the Interface 1000.

Gamry's synchronization system uses the terms Master and Serf as defined below.

Master: The Master potentiostat provides the clock signal used for all potentiostats and provides data acquisition pulses used to control the timing of A/D conversion. All synchronous multiple potentiostat systems have only one Master.

Serf: A Serf potentiostat gets its timing information from a Master potentiostat. A multiple potentiostat system can have up to 7 Serf potentiostats all controlled by one Master.

A special cable is used to connect the instruments that will be synchronized. The cable has a Master connector on one end and a variable number of Serf connectors.

Gamry sells three standard Master-Serf cables:

- 985-132 One Master and One Serf
- 985-133 One Master and up to Three Serfs
- 985-134 One Master and up to Seven Serfs

All of these cables have the Master end of the cable identified by a large M on the DIN connector. Note that a cable can be used with some instruments missing, so the eight instrument Master -Serf cable can be used for one Serf, two Serfs, three Serfs,..., seven Serfs.

Note

We recommend that you always plug the Master and last Serf ends of the cable into a potentiostat. You can leave of the DIN connectors in the middle of the cable disconnected.

The Master-Serf connection scheme sends 24 MHz complex clock signal from the Master to the Serfs using a daisy-chained low voltage differential signal (LVDS). Data acquisition pulses are imbedded in the clock signal. DC pins in the DIN connector are used to detect all cable connections and most importantly detect the Master end of the cable.

We ask that you use Gamry supplied cables for all Master - Serf synchronized systems. The cable uses a differential pair that requires controlled impedance making user construction of a cable very difficult.

Monitor Connector

The Monitor Connector is located on the Interface 1000 Front Panel. It is an 8-pin round mini-DIN connector. One possible mating connector is from CUI Inc. part number MD-80. The pin out of the Monitor Connector is shown in Table C-2.

**Table C-2
Monitor Connector**

Pin	Name	Use
1	Unreg +5 V	An unregulated source of +5 V. 10 Ω output impedance.
2	Signal Ground	A very high quality ground. Signals are relative to this ground
3	Power Ground	Ground used when active circuits are needed. Power circuits from Pin 1 to Pin 3.
4	Signal Ground	A very high quality ground. Signals are relative to this ground
5	E_sig	E Monitor Signal
6	EXT_SIG	External Signal In
7	I_Sig	I_Monitor Signal
8	Signal Ground	A very high quality ground. Signals are relative to this ground

I Monitor Signal

The I Monitor signal represents the output of the Interface 1000 current measurement circuit. It can be treated as a 2-wire differential signal with the negative side connected to the Interface 1000 Signal Ground. With the exception of the filtering described below, it is the raw signal with no offset or gain applied. The effective bandwidth of the current signal falls as you reach the nA and pA current ranges. IE Stability capacitors further slow the response.

Caution

The ground side of the I Monitor signal is connected to the Interface 1000 Floating Ground. Connection signal to an earth ground referenced apparatus can compromise the Interface 1000's ability to float and invalidate data collected on earth grounded cells.

Scaling on this signal is ± 3 volts for \pm the nominal full scale current on the selected current range. Cathodic currents will cause a positive output voltage. If the software is auto-ranging the current-range selection, this signal will be discontinuous at each range change.

The I Monitor signal is filtered using an RLC circuit. It has a bandwidth of approximately 150 kHz when connected to a high impedance input. This bandwidth will be further reduced if a coaxial cable is connected to the BNC. Its output impedance is approximately 1 k Ω in parallel with 47 pF.

E Monitor Signal

The E Monitor signal is derived from the output of the Interface 1000's differential electrometer circuit. It can be treated as a 2-wire differential signal with the negative side connected to the Interface 1000 Signal Ground. With the exception of the filtering described below, it is the raw voltage signal, with no offset or gain applied. With the exception of the filtering described below, it is buffered representation of the voltage difference between the white and blue cell cable leads.

Caution

The negative side of the E Monitor signal is connected to the Interface 1000 Floating Ground. Connection of signal to an earth ground referenced apparatus can compromise the Interface 1000's ability to float and invalidate data collected on earth grounded cells.

The E Monitor signal is filtered using an RLC circuit. It has a bandwidth of approximately 150 kHz when connected to a high impedance input. This bandwidth will be further reduced if a coaxial cable is connected to the BNC. Its output impedance is approximately 1 k Ω in parallel with 47 pF.

External Signal In

External Signal In allows you to add a voltage to the Interface 1000's Signal Generator. It is a 2-wire differential signal with the negative side connected to the Interface 1000 floating ground. This signal will be summed with the other signal generator sources including the Bias DAC, the Scan DAC, and the DDS output.

Caution

The negative side of the External Signal In signal is connected to the Interface 1000 Floating Ground. Connection of this signal to earth ground referenced apparatus can compromise the Interface 1000's ability to float and invalidate data collected on earth grounded cells.

The signal generator output is directly connected to the potentiostat's input. When the cell is turned on in potentiostat mode, the feedback is such that a negative signal generator output creates a positive differential electrometer signal, which corresponds to a negative working electrode versus reference electrode voltage.

The polarity of the External Signal In signal is inverted at the signal generator's output. As described above, a negative input signal on this BNC will create a positive change in the working electrode versus reference electrode voltage. The input impedance of this signal is 2 k Ω .

Appendix D – Power LED Blink Codes

In the rare event that some electronics module fails, we include the start-up blink codes that the blue Power LED flashes. Upon start-up, view the Power LED. If it blinks more than five times, or flashes one of the blink-codes below, please call Gamry Instruments for service.

Normal Start-up

The Power LED flashes three times.

Failure in an electronics module

The Power LED flashes codes depending upon the failed module:

Problem	Power LED blink code
Post SDRAM unidentified problem	Twice, then once
Post SDRAM size error	Twice, then twice
Post ROM checksum error	Twice, then three times
Post Serial init. RX buffer	Three times, then four times
Post Serial init. TX buffer	Three times, then five times
Post Serial init. UART	Three times, then six times
Post Communications module missing	Three times, then eight times
Post Control missing	Four times, then once
Post potentiostat missing	Four times, then twice

If there are multiple problems, the communications board takes code priority over the memory module.

Severe problem

The red LED, which normally switches off after a rapid boot-up, remains illuminated.



If you receive one of the above codes, please call Gamry Instruments Service Department for assistance.

Error Messages and Limitations

The Interface 1000 has a subtype, Interface 1000T, which may generate error messages under certain run-time conditions.

Error Message This instrument is not authorized for Freq=

The Interface 1000T is able to perform EIS at frequencies 20 kHz or lower. Higher frequencies generate this error message. Decrease the upper frequency to continue.

Error Message This instrument is not authorized for IERange=

The Interface 1000T is able to operate at currents of 100 mA or lower. Higher currents generate this error message. Decrease the current to continue.

Error Message This instrument is not authorized for ScanRate=

The Interface 1000T is able to scan at rates of 1 V/s or lower. Higher scan rates generate this error message. Decrease the scan rate to continue.

Error Message "This instrument is not authorized for SampleTime=

The Interface 1000T is able to record data with a sample time of 1 ms or higher. Shorter sample times generate this error message. Increase the sample time to continue.

Appendix E – CE Certificate



Declaration of Conformity

According to ISO/IEC Guide 22 and CEN/CENELEC EN 45014

Manufacturer's Name and Location:

Gamry Instruments
734 Louis Drive
Warminster, PA 18974
USA

This declaration is for the Gamry Instruments product: Interface 1000 Potentiostat/Galvanostat/ZRA.

The declaration is based upon compliance with the following directives:

EMC Directive 2004/108/EC

Low Voltage Safety Directive 2006/95/EC

The declaration is based upon product compliance with the following standards as defined in report number 05965-000 from Ergonomics, Inc. for safety analysis and report number R-1789P from Retlif Testing Laboratories, Inc. for EMC test and analysis.

EMC Standards	Title	Class/ Criteria
EN 61326-1:2006 Table 1	EMC – Electrostatic discharge, Immunity	B
EN 61326-1:2006 Clause 7.2	EMC – Emissions	A

Low Voltage Directive Safety Standards	Title
EN 61010-1:2010	Safety requirements for electrical equipment for measurement, control and laboratory use, Part 1: General requirements.

Signature

May 18, 2012
Date

Dr. Gregory A. Martinchek, PhD
Title: President

Formal signed declaration is on file at Gamry, Inc.

Low Voltage Certificate of Conformance



PO Box 964 / Southampton, PA 18966
Phone: 800-862-0102 / 215-357-5124
Fax: 215-364-7582
e-mail: info@ergonomicsusa.com
website: www.ergonomicsusa.com

Certificate of Conformance

European Community Low Voltage Directive 2006/95/EC

Certificate Issued to:
Gamry Instruments
734 Louis Drive
Warminster, PA 18974
USA

Manufacturing Location:
Gamry Instruments
734 Louis Drive
Warminster, PA 18974
USA

This certificate is only issued for the products described and listed in Ergonomics, Inc. Report Number R0596-000

Product tested:
The product tested was model Interface 1000, serial number 992-00088. Consult the report for full range of products included in this certificate.

Issued by:
Ergonomics, Inc.
324 Second Street Pike
Southampton, PA 18966
USA

A handwritten signature in black ink that reads "David L. George".

David L. George, PE, Director

Applicable Standard:

EN 61010-1:2010 - Safety requirements for electrical equipment for measurement, control and laboratory use - Part 1: General Requirements.

Date of Issue: March 6, 2012

RFI Certificate of Conformance

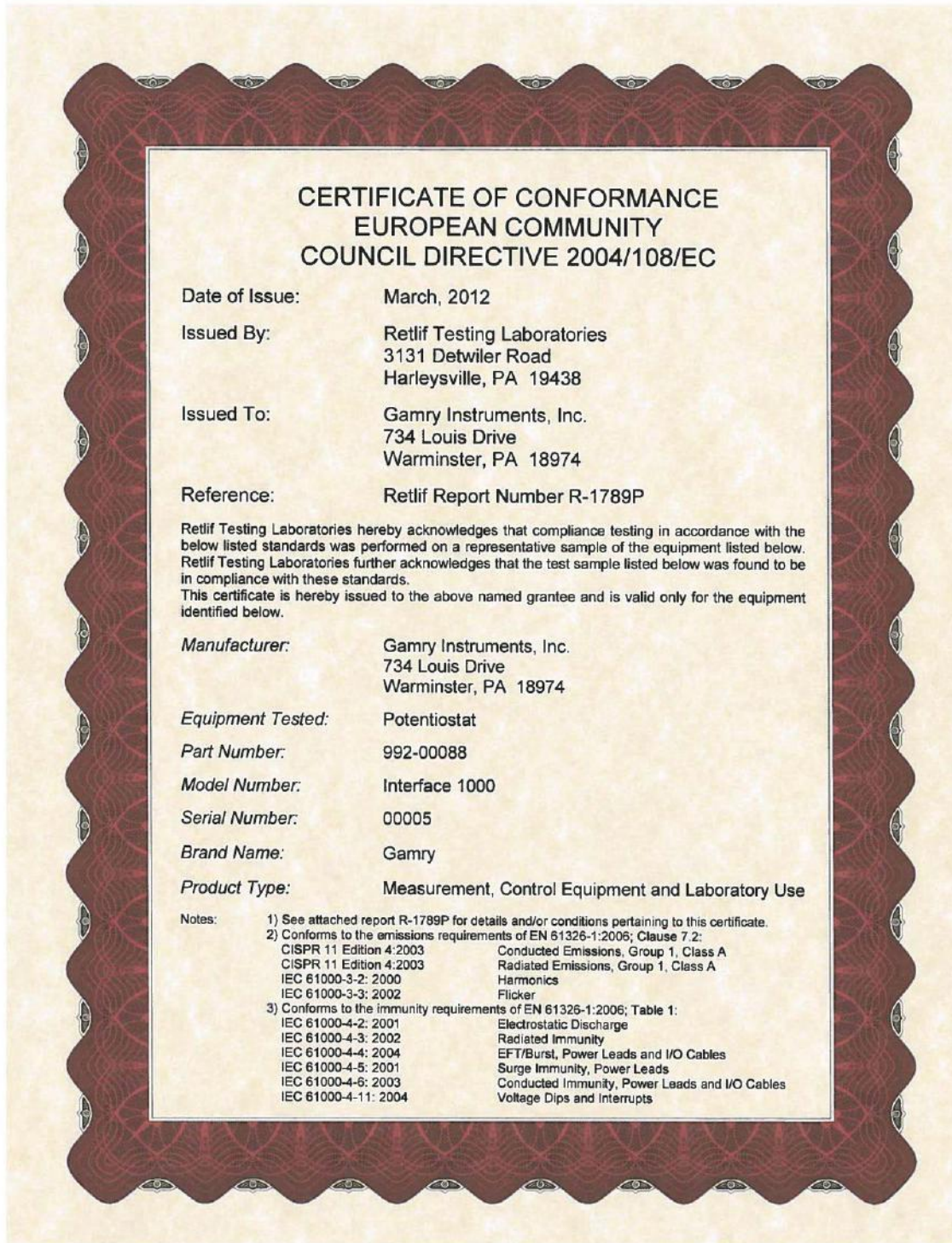

Appendix E – CE Certificate

Appendix F -- Heat in Interface 1000 MultEchem Systems

Introduction to Device Power Dissipation

All electronic devices require power to operate. In most cases, this power generates heat within the device. The simplest model for device power assumes the device can be modeled as a simple resistor across the power supply inputs. This simple, but often useful, model ignores the details of internal power supplies within the device, active circuitry, and power in I/O circuitry.

The power dissipated in a resistor is given by:

$$P = V \cdot I = I^2 R = \frac{V^2}{R}$$

P is power in Watts, V is voltage in Volts, I is current in Amperes, and R is the resistance in Ohms.

In this simple model, a device powered from +48 volts with a power supply current of 0.1 Ampere will dissipate the same power as a 480 Ω resistor – 4.8 W.

Normally the power supply voltage is assumed to be constant, so a device's power depends on the current requirements which vary with the device's operating conditions.

Figure E-1
Interface 1000 Simplified Power Model

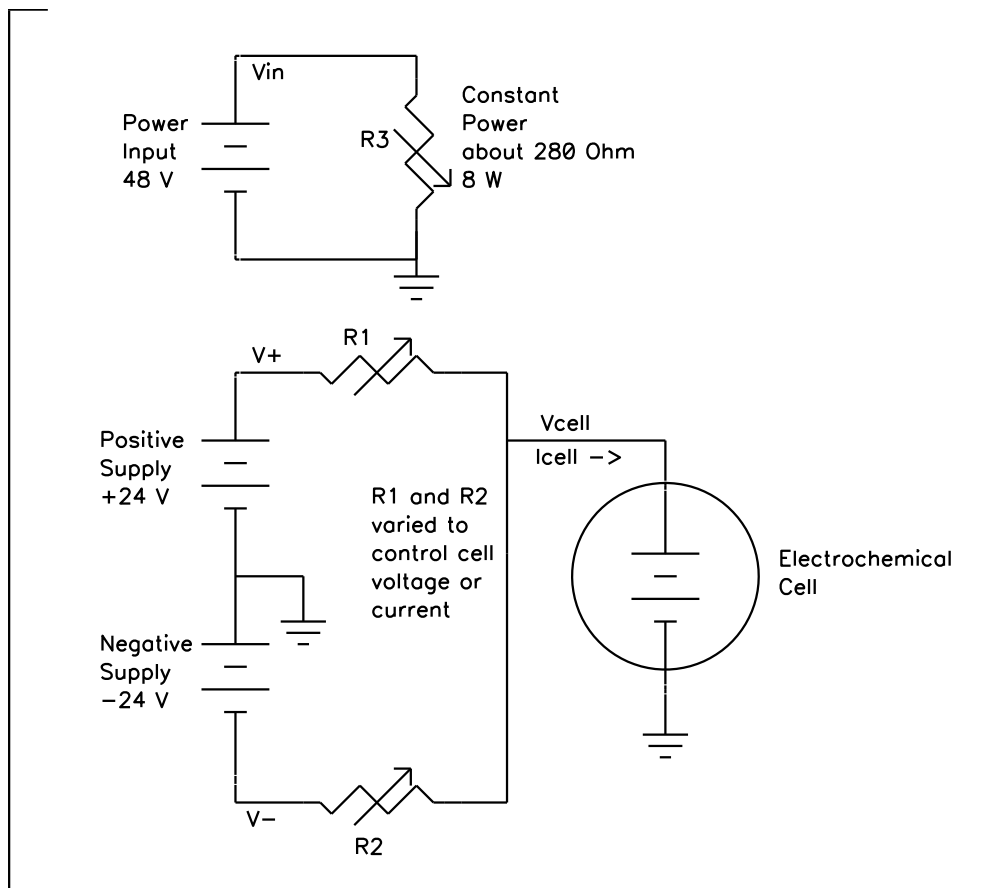

Potentiostat/Galvanostat Power Model

A potentiostat requires a somewhat more sophisticated power dissipation model. A simple potentiostat power model can be found in the preceding figure. The electrochemical cell has a voltage V_{cell} that plays a role in the instrument's power dissipation.

The variable resistors take different values depending on the potentiostat/galvanostat's operating conditions. The upper portion of the model describes a fairly constant power draw in the Interface 1000 circuitry. This power comes from the normal operation of the instrument: running its microprocessor, powering its operational amplifiers and D/A and A/D converters, etc. There is some variability in this power depending on signal levels in the analog circuitry, probably from 6 to 10 W, but 8 W can be assumed.

The lower portion of the figure shows the power effects that come from the Interface 1000 power amplifier polarizing the electrochemical cell. V_+ and V_- are 24 volt power supplies generated within the Interface 1000. R_1 and R_2 model the power MOSFET transistors that control current flow through the cell.

When the cell current and cell voltage are both small, R_1 and R_2 have approximately equal values: about 240 Ω . This creates a steady state current of about 100 mA through R_1 and R_2 , resulting in "quiescent" power dissipation of a little less than 5 W.

The values of R_1 and R_2 change when current flows into or out of the cell. When +1A flows into a zero voltage cell, R_1 is around 24 Ω and R_2 becomes very large. In this condition, power amplifier dissipation is 24 W and the total device power is about 32 W.

The Interface 1000's total power dissipation with the cell polarized is approximated by:

$$P = \frac{V_{in}}{R_3} + \frac{(V_+ - V_{cell})^2}{R_1} + \frac{(V_{cell} - V_-)^2}{R_2}$$

With large cell currents, the current from one leg of the circuit dominates power amplifier dissipation and total device power becomes:

$$P = \frac{V_{in}}{R_3} + (V_+ - V_{cell}) I_{cell}$$

or

$$P = \frac{V_{in}}{R_3} + (V_{cell} - V_-) I_{cell}$$

Note that V_{cell} can be either positive or negative.

Power dissipation within the Interface 1000 raises the temperature within the unit and on the exterior of the unit. In rare cases, the temperature increase can create an over-temperature event, upon which the unit shuts off the cell current and enters a protective latch-up state. You can only recover from this state by turning off the power on the Interface 1000, waiting for the device to cool, and turning the power back on.

Discharging a Battery

The highest power application for a potentiostat is discharging a battery stack (or a stack of other energy storage devices such as electrical double layer capacitors or fuel cells). Unlike single cells, stacks can have voltages that stress the power dissipation capabilities of a potentiostat. In the calculations that follow, 8 W of load independent power dissipation is assumed.

Let's look at the power in three typical, high current battery discharges:

- If we only have a single battery and its voltage is 5 V, the maximum power dissipation is 37 W.
- If the battery stack has a voltage equal to the largest measurable Interface 1000 cell voltage (12 Volts) the maximum power dissipation in the instrument is 44 W.
- In an unusual experiment, a resistive voltage divider on the voltage measurement could allow Interface 1000 operation with battery stacks with voltages as high as 20 V. In this case, the maximum total power dissipation is 52 W.

Note that the maximum power drawn from the instrument's power input jack is largely independent of the cell voltage. The maximum is 32 W (divided by the power supply efficiency). The higher power levels mentioned above occur because the battery is sourcing power.

Single Interface 1000

Gamry has tested a single Interface 1000 operating at its most extreme condition: discharge of a 20 Volt cell at 1 A current. The unit was run in its normal horizontal position, with 1 A cell current and a 20 V cell voltage. The air-flow through the unit was unimpeded.

In this test, the unit could be operated indefinitely, with no over-temperature events seen, even with a 45 °C ambient temperature. The highest temperature measured on the outside of the Interface 1000 chassis was 15 °C above ambient.

Vertical Stacks

Gamry also tested a system with four Interface 1000s stacked one atop another (a vertical stack of horizontal units). In this configuration, the Interface 1000s run hotter, since power dissipation in one unit can radiate heat to adjacent units and also preheat the air used to cool other units. The units higher in the stack run hotter because their cooling air is preheated by the units below them. The cooling air entering the unit on the bottom of the stack is unheated, so this unit runs significantly cooler than all the others.

We saw over-temperature events in this configuration when the units are operated at the unusual condition of discharging a 20 V battery. The over-temperature events occurred on upper units and only occurred after at least 20 minutes of continuous worst case power operation. The case of the hottest Interface 1000 was also more than 25 °C above ambient.

The system operated indefinitely with no problems when the cell voltage was limited to 12 V or less. The highest temperature measured on the outside of hottest Interface 1000 chassis was 20 °C above ambient.

Interface Power Hub Systems

The Interface Power Hub uses forced air cooling to lower temperatures in stacked Interface 1000s. The units are turned 90° to run in an array of vertical instruments.

Gamry tested a system with eight Interface 1000s mounted in an Interface Power Hub. All units were operated at the worst case condition of 52 W power dissipation - discharge of a 20 V cell at 1 A.

In this test, the system could be operated indefinitely with no over-temperature events seen, even with a 45 °C ambient temperature. The top of the Interface Power Hub chassis got warm, but stayed at less than 15 °C above ambient.

Comprehensive Index

25 pin D, 3-5

AC adapter, 1-1
 ADC channels, 6-4
 air-cooling, 1-3
 alligator clip, 4-2
 ancillary apparatus, 8-7
 authorization code \c chapter, 3-10
 auxiliary electrode, 4-1

black banana, 4-1
 blink codes, 3-4, 9-1
 Blink Codes, 9-1
 blue cell lead, 4-1

calibration, 3-14
 calibration data, 6-5
 capacitive cells, 7-1
 CE Compliance, 1-6
 cell cable, 4-1
 replacements and specials, 4-2
 ZRA connections, 4-2

Cell Connector, 3-5, 5-1, 9-1
 cell construction materials, 8-6
 Cell LED, 5-2
 Chassis Ground, 5-4
 cleaning, 1-4
 computer, 2-2
 computer requirements, 3-2
 computers - noise, 8-5
 contract engineering, ii
 Control Overload, 5-3
 conventions
 notational, 2-3
 Counter Electrode, 4-1, 9-1
 Counter Sense, 9-1

data storage, 6-5
 DC voltage, 6-6
 DDS, 6-3
 double insulation, 1-1, 3-1

E Overload, 5-3
 earth ground, 1-2, 8-5, 8-7
 EIS speed, 8-7
 electrical noise, 8-5
 electrical transients, 1-5
 electrons per second, 8-1
 enclosed space, 1-3

environmental limits, 1-4
 environmental stress, 1-4
 External Signal, 9-3

fan speed, 1-3
 Faraday shield, 4-2, 8-5
 filters, 6-4
 firmware download, 5-2
 firmware update, 3-12
 Floating Ground, 4-1, 5-4
 floating ground binding post, 1-2
 floating operation, 8-7
 fluorescent lights, 8-5

Gamry Framework, 2-1
 green cell lead, 4-1
 ground, 9-1

Help system, 2-1
 high frequency shunt, 7-3
 high speed USB, 5-4
 hints – cell design, 8-5
 horizontal stack, 9-3

I Overload, 5-3
 I/O connector, 5-5
 input capacitance, 8-1
 input current, 8-1
 input impedance, 8-1
 input leakage current, 8-3
 inspection, 1-1
 installation, 3-1
 Instrument Manager, 3-9
 Interface Power Hub, 2-2, 9-3

Johnson noise, 8-2

label, 3-16
 label files, 3-16
 lead capacitance, 8-6
 lead placement, 8-6
 Luggin capillaries, 8-6
 Luggin capillary, 7-2

manual overview, 2-1
 Master, 9-1
 materials, 8-6
 measurement system model, 8-1
 membrane cell connections, 4-3
 Monitor Connector, 5-1
 motors, 8-5

noise, 8-4

operation, 1-4

orange lead, 4-1

oscillation, 7-1

Overload LED, 5-3

over-temperature event, 9-2

overview, 2-1

personalization label, 3-16

power brick, 1-1

Power Connection, 3-3

Power Cord, 3-3

Power Dissipation, 9-1

Power In, 5-4

Power LED, 3-4, 3-9, 5-1, 5-2, 9-1

power line transient, 1-5

Power PC, 6-5

Power switch, 3-4

radio frequency, 1-5

radio transmitters, 8-5

red cell lead, 4-1

Reference Electrode, 4-1, 9-1

reference electrode impedance, 8-6

ringing, 7-1

safety, 1-1

schematic, 6-1

Serf, 9-2

service, 1-5

service contract, ii

shielding against noise, 1-2

small signals, 8-1

software calibration, 8-1

specifications, 8-1

stability, 7-1

state-machine, 6-4

static electricity, 1-5

storage, 1-4

support, ii

Sync port, 2-2

Synch Port, 5-5, 9-1

telephone assistance, ii

temperature, 1-3

Universal Dummy Cell, 3-14

USB cable, 3-4

USB LED, 3-5, 5-2

USB port, 5-4

USB Processor, 6-5

User I/O connector, 5-5

ventilation, 1-3, 3-2

Visual Inspection, 3-1

voltage noise, 8-4

Warranty, iii

WE Shield, 9-1

white cell lead, 4-1

Windows Update, 3-6

Working Electrode, 4-1, 9-1

Working Sense, 9-1

WS Shield, 9-1

ZRA

cell connections, 4-2