

Measurement of Small Electrochemical Signals

Introduction

Potentiostats are often called on to work near the limits of measurement science. The Gamry Instruments Reference 600 can resolve current changes as small as 1 femtoamp (10^{-15} amps). To place this current in perspective, 1 fA represents the flow of about 6000 electrons per second!

Small current measurements place demands on the instrument, the cell, the cables and the experimenter. Many of the techniques used in higher current electrochemistry must be modified when used to measure pA and fA currents. In many cases, the basic physics of the measurement must be considered.

This Application Note will discuss the limiting factors controlling low current measurements. The emphasis will be on EIS (Electrochemical Impedance Spectroscopy), a major application for low current potentiostats.

Measurement System Model and Physical Limitations

To get a feel for the physical limits implied by femtoamp measurements, consider the equivalent circuit shown in the following figure. We are attempting to measure a cell impedance given by Z_{cell} .

This model is valid for analysis purposes even when a real potentiostat's circuit topology differs significantly.

In Figure 1,

- E_s = an ideal signal source
- Z_{cell} = the unknown cell impedance
- R_m = the current measurement circuit's current measurement resistance
- R_{shunt} = an unwanted resistance across the cell
- C_{shunt} = an unwanted capacitance across the cell
- C_{in} = the current measurement circuit's stray input capacitance
- R_{in} = the current measurement circuit's stray input resistance
- I_{in} = the measurement circuit's input current

In the ideal current measurement circuit R_{in} is infinite while C_{in} and I_{in} are zero. All the cell current, Z_{cell} , flows through R_m .

With an ideal cell and voltage source, R_{shunt} is infinite and C_{shunt} is zero. All the current flowing into the current measurement circuit is due to Z_{cell} .

The voltage developed across R_m is measured by the meter as V_m . Given the idealities discussed above, one can use Kirchoff's and Ohm's law to calculate Z_{cell} :

$$Z_{cell} = E_s * R_m / V_m$$

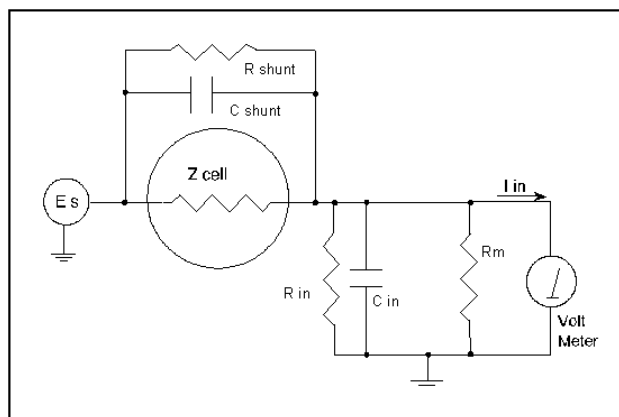

Figure 1. Equivalent Measurement Circuit.

Unfortunately technology limits high impedance measurements because:

- Current measurement circuits always have non-zero input capacitance, i.e. $C_{in} > 0$,
- Infinite R_{in} cannot be achieved with real circuits and materials,
- Amplifiers used in the meter have input currents, i.e. $I_{in} > 0$,
- The cell and the potentiostat create both a non-zero C_{shunt} and a finite R_{shunt} .

Additionally, basic physics limits high impedance measurements via Johnson noise, which is the inherent noise in a resistance.

Johnson Noise in Z_{cell}

Johnson noise across a resistor represents a fundamental physical limitation. Resistors, regardless of composition, demonstrate a minimum noise for both current and voltage, per the following equation.

$$E = (4kTR \text{ dF}) \frac{1}{2} \quad (1)$$

$$I = \left(\frac{4kT \text{ dF}}{R}\right) \frac{1}{2} \quad (2)$$

where,

k = Boltzman's constant 1.38×10^{-23} J/°K

T = temperature in °K

dF = noise bandwidth in Hz

R = resistance in ohms

For purposes of approximation, the noise bandwidth, dF, is equal to the measurement frequency. Assume a 10^{12} ohm resistor as Z_{cell} . At 300°K and a measurement frequency of 1 Hz this gives a voltage noise of 129 mV rms. The peak to peak noise is about 5 times the rms noise. Under these conditions, you cannot make a voltage measurement of ± 10 mV across Z_{cell} without an error of up to $\pm 3\%$. Fortunately, an AC measurement can reduce the bandwidth by integrating the measured value at the expense of additional measurement time. With a noise bandwidth of 1 mHz, the voltage noise falls to 4 mV rms.

Current noise on the same resistor under the same conditions is 0.129 fA. To place this number in perspective, a ± 10 mV signal across this same resistor will generate a current of ± 10 fA, or again an error of up to $\pm 3\%$. Again, reducing the bandwidth helps. At a noise bandwidth of 1 mHz, the current noise falls to 0.004 fA.

With E_s at 10 mV, an EIS system that measures 10^{12} ohms at 1mHz is about 3 decades away from the Johnson noise limits. At 0.1 Hz, the system is close enough to the Johnson noise limits to make accurate measurements impossible. Between these limits, readings get progressively less accurate as the frequency increases.

In practice, EIS measurements usually cannot be made at high enough frequencies that Johnson noise is the dominant noise source. If Johnson noise is a problem, averaging reduces the noise bandwidth, thereby reducing the noise at a cost of lengthening the experiment.

Finite Input Capacitance

C_{in} in Figure 1 represents unavoidable capacitances that always arise in real circuits. C_{in} shunts R_m , draining off higher frequency signals, limiting the bandwidth that can be achieved for a given value of R_m . This calculation shows at which frequencies the effect becomes significant. The frequency limit of a current measurement (defined by the frequency where the phase error hits 45°) can be calculated from:

$$f_{RC} = \frac{1}{2pR_m C_{in}} \quad (3)$$

Decreasing R_m increases this frequency. However, large R_m values are desirable to minimize voltage drift and voltage noise.

A reasonable value for C_{in} in a practical, computer controllable low current measurement circuit is 5 pF. For a 30 pA full scale current range, a practical estimate for R_m is 10^{10} ohms.

$$f_{RC} = 1 / 6.28 (1 \times 10^{10}) (5 \times 10^{-12}) \gg 3 \text{ Hz}$$

In general, one should stay two decades below f_{RC} to keep phase shift below one degree. The uncorrected upper frequency limit on a 30 pA range is therefore around 30 mHz.

One can measure higher frequencies using the higher current ranges (i.e. lower impedance ranges) but this would reduce the total available signal below the resolution limits of the "voltmeter". This then forms one basis of statement that high frequency and high impedance measurements are mutually exclusive.

Software correction of the measured response can also be used to improve the useable bandwidth, but not by more than an order of magnitude in frequency.

Leakage Currents and Input Impedance

In Figure 1, both R_{in} and I_{in} affect the accuracy of current measurements. The magnitude error due to R_{in} is calculated by:

$$\text{Error} = 1 - R_{in} / (R_m + R_{in}) \quad (4)$$

For an R_m of 10^{10} ohms, an error $< 1\%$ demands that R_{in} must be $> 10^{12}$ ohms. PC board leakage, relay leakage, and measurement device characteristics lower R_{in} below the desired value of infinity.

A similar problem is the finite input leakage current (lin) into the voltage measuring circuit. It can be leakage directly into the input of the voltage meter, or leakage from a voltage source (such as a power supply) through an insulation resistance into the input. If an insulator connected to the input has a 10^{12} ohm resistance between +15 volts and the input, the leakage current is 15 pA. Fortunately, most sources of leakage current are DC and thus they disappear in impedance measurements. As a rule of thumb, the DC leakage should not exceed the measured signal by more than a factor of 10.

The best commercially available input amplifier has input current of around 50 fA. Other circuit components may also contribute leakage currents. You therefore cannot make absolute current measurements of low fA currents. In practice, the input current is approximately constant, so current differences or AC current levels of a few fA can be measured.

Voltage Noise and DC Measurements

Often the current signal measured by a potentiostat shows noise that is not the fault of the current measurement circuit. This is especially true when you are making DC measurements. The cause of the current noise is noise in the voltage applied to the cell.

Assume that you have a working electrode with a capacitance of 1 mF. This could represent a passive layer on a metal specimen. The impedance of this electrode, assuming ideal capacitive behavior, is given by

$$Z = \frac{1}{j\omega C} \quad (5)$$

At 60 Hertz, the impedance value is about 2.5 kW.

Apply an ideal DC potential across this ideal capacitor and you get no DC current.

Unfortunately, all potentiostats have noise in the applied voltage. This noise comes from the instrument itself and from external sources. In many cases, the

predominant noise frequency is the AC power line frequency.

Assume a reasonable noise voltage, V_n , of 10 mV. Further, assume that this noise voltage is at the US power line frequency of 60 Hz. It will create a current across the cell capacitance:

$$I = V_n/Z \gg 4 \text{ nA}$$

This rather large noise current will prevent accurate DC current measurement in the pA range.

In an EIS measurement, you apply an AC excitation voltage that is much bigger than the typical noise voltage, so this is not a factor.

Shunt Resistance and Capacitance

Non-ideal shunt resistance and capacitance arise in both the cell and the potentiostat. Both can cause significant measurement errors.

Parallel metal surfaces form a capacitor. The capacitance rises as either metal area increases and as the separation distance between the metals decreases.

Wire and electrode placement have a large effect on shunt capacitance. If the clip leads connecting to the working and reference electrodes are close together, they can form a significant shunt capacitor. Values of 10 pF are common. This shunt capacitance cannot be distinguished from "real" capacitance in the cell. If you are measuring a paint film with a 30 pF capacitance, 10 pF of shunt capacitance is a very significant error.

Shunt resistance in the cell arises because of imperfect insulators. No material is a perfect insulator (one with infinite resistance). Even Teflon, which is one of the best insulators known, has a bulk resistivity of about 10^{14} ohms. Worse yet, surface contamination often lowers the effective resistivity of good insulators. Water films can be a real problem, especially on glass.

Shunt capacitance and resistance also occur in the potentiostat itself. In most cases, the cell's shunt resistance and capacitance errors are larger than those from the potentiostat.

Measurement of Small Electrochemical Signals. Rev. 2.0.
1/17/2011 © Copyright 1990-2011 Gamry Instruments, Inc.

